

Drive Solutions for the Oil and Gas Industry

metals

cranes

mining

testing

oil & gas

solar inverters

utilities

cement

About TMEiC

A Global network

TMEiC is built on the combined and proud heritage of Toshiba and Mitsubishi-Electric in the industrial automation, control and drive systems business. TMEiC's global business employs more than 2,200 employees, with sales exceeding U.S. \$2.4 billion, and specializes in Metals, Oil & Gas, Material Handling, Utilities, Cement, Mining, Paper and other industrial markets.

TMEiC Corporation, headquartered in Roanoke, Virginia, designs, develops and engineers advanced automation and variable frequency drive systems.

The factory for the World's factories

TMEiC delivers high quality advanced systems and products to factories worldwide, while serving as a global solutions partner to contribute to the growth of our customers.

Customer Service

At TMEiC, our focus is on the customer, working to provide superior products and excellent service, delivering customer success every project, every time.

Variable Speed Drives in the Oil & Gas Industry

Every step of the way, from the wellhead to the finished fuel products, large, variable-speed drives are used to start motors and control flow.

In **gas & oil pipelines**, driving large pumps and compressors, varying speed to control flow – see Application 3, page 10.

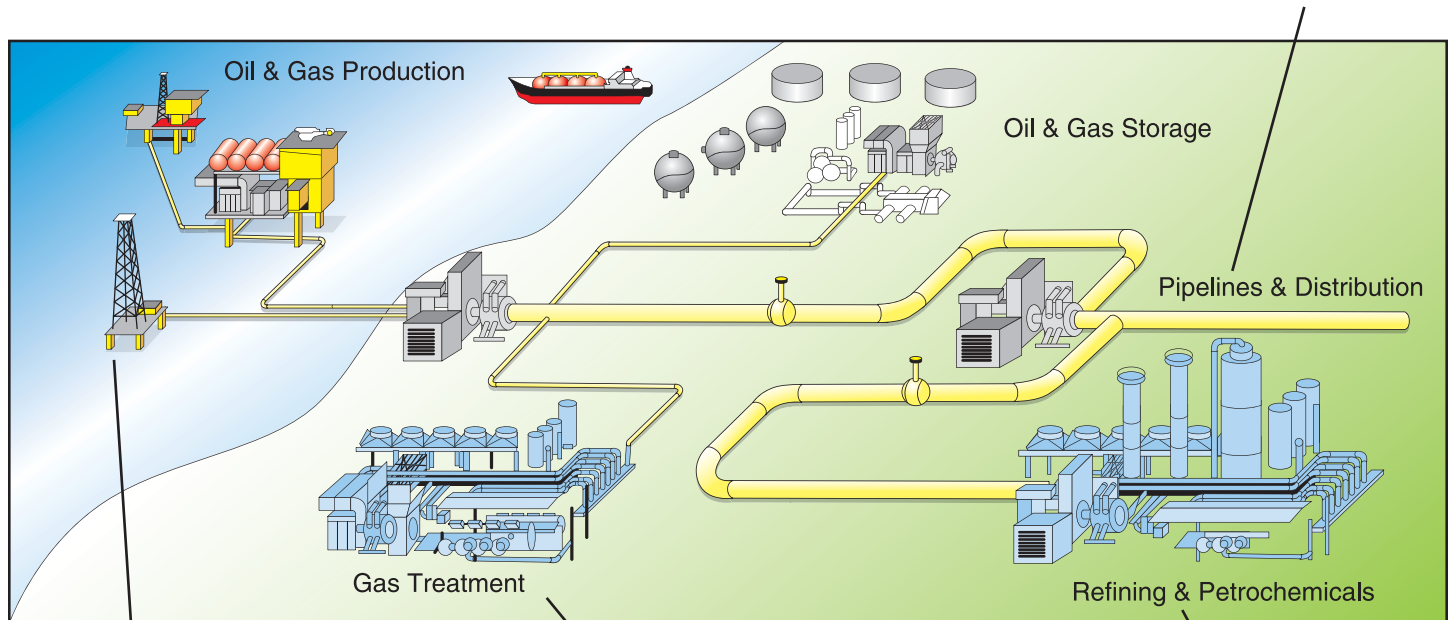

In **offshore platforms**, driving gas compressors and oil pumps, moving fluids to onshore – see Application 2, page 8.

In **liquefied natural gas plants**, driving large compressors and varying speed to control flow – see Application 4, page 12.

In **refineries**, driving large compressors and varying speed to control flow – see Application 1, page 6.

The compressors and pumps use drives to smoothly start the large motors and continuously adjust the speed to control flow. Controlling flow by adjusting speed avoids energy wasted in the throttling valves. When large flows are involved and the motor energy consumption is significant, varying the speed is the answer.

With large machines, the electrical power savings amount to hundreds of thousands of dollars per year. In addition, the motor is protected against starting inrush currents, and control valve maintenance expenses and resulting downtime are minimized.

Why Use Electrical Variable Speed Drives?

Here are some of the reasons to use electrical medium voltage drives:

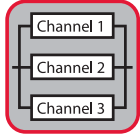

Increased Reliability

Pages 5, 6

Variable speed motor-drive systems are more reliable than traditional approaches as such using turbines to control flow. They can also be configured in redundant channel configurations such as triple module redundancy (TMR) for very high reliability



Dramatic Energy Savings

Pages 5, 6, 10

With a variable speed motor-drive system, the flow control valve is not required, avoiding large flow energy losses. In fact, the variable speed motor-drive system is more efficient than all other flow control methods including turbines and hydraulic transmissions. For more information on this topic, refer to *Selecting Variable Speed Drives for Flow Control* in the library at www.tmeic.com.



Significantly Less Maintenance

Pages 5, 6

The oil & gas industry is all about system availability; variable speed motor-drive systems require virtually no maintenance. This is in sharp contrast to flow control valves, guide vanes, and turbines that do require extensive periodic maintenance and associated downtime.



Air & Noise Pollution Virtually Eliminated

Pages 6, 12

Gas turbines driving compressors can generate significant air and noise pollution. In populated areas, this can be a serious issue. Variable speed motor-drive systems generate no air pollution and negligible noise.

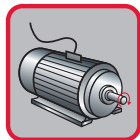

Soft Starting One or Multiple Motors, and Power Factor Correction

Pages 6, 9

When electric drives start large motors, starting inrush current with associated mechanical and thermal wiring stress is eliminated. This removes limitations on motor frequency of starts, reduces insulation damage, and provides extended motor life. With synchronization logic, one drive can start multiple motors. Many large drive configurations also improve overall system power factor.

Why TMEIC Drives Make Sense



Choose TMEIC, a Global Supplier

Page 20

TMEIC sells and services drive systems worldwide, supported by engineering and service offices and spare parts depots in North & South America, Europe, Asia, Japan and Australia.



We've got you covered! A Complete Family of Drives

Page 21

Our family of medium voltage (MV) drives covers all your needs from 450 hp up to 120,000 hp (335 kW to 90,000 kW); with a wide voltage range up to 7.2 kV to meet your requirements.

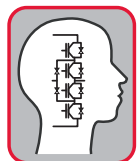

Engineering Expertise

Page 14

TMEIC drive and motor application engineers bring an average of 25 years of practical industry experience to your application. After analyzing your system requirements, they can recommend the most cost effective solution and design the complete drive system for you.



Configuration Software

Pages 17, 22, 24

The TMdrive Navigator world-class configuration software is used on all TMEIC drives. Live block diagrams and tune-up wizards streamline commissioning and maintenance activities.

Comparison of Electrical & Mechanical Flow Control Methods

Flow Control Methods		Power Train			
Electrical Drives	Electric Frequency Control Three-Phase Electric Supply TMdrive-70 Electric Adjustable Speed Drive (ASD) 96.4% * Annual Electric Cost \$1,358,709	2,216 kW	2,136 kW	2,094 kW	1,780 kW
	Electric Frequency Control Three-Phase Electric Supply LCI Redundant Elect. ASD (Channel 1, 2, 3) 97.3% * Annual Electric Cost \$1,346,604	2,196 kW	2,136 kW	2,094 kW	1,780 kW
Mechanical Control	Valve Control Three-Phase Electric Supply Motor Starter * Annual Electric Cost \$1,654,388	2,698 kW	2,644 kW	2,094 kW	1,780 kW
	Hydraulic Variable Speed Control Three-Phase Electric Supply Motor Starter * Annual Electric Cost \$1,416,492	2,310 kW	2,264 kW	2,094 kW	1,780 kW
	Steam or Fuel Control Steam, Gas, or Kerosene Fuel or Steam Control * Annual Gas Cost \$1,963,084	5,659 kW	2,094 kW	2,094 kW	1,780 kW

* Common conditions for above cases:

- Nominal 4,000 hp compressor
- Continuous operation at 85% rated speed or equivalent flow

- LCI drive is the basis for cost comparison
- Synchronous motor is used, efficiency 98% (induction motor efficiency is 95%)
- Gas turbine has 37% thermal efficiency

- LCI has 97.3% efficiency
- Power cost \$0.07/kWh.
- Natural gas cost, industrial rate, Dec. 2005, is \$12.00/1,000 cu ft

Save Energy, Increase Reliability, Control Motor Current, Reduce Pollution, Reduce Noise

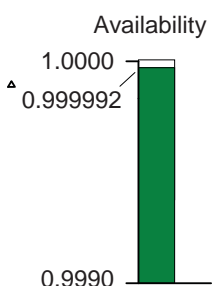
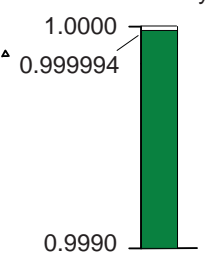
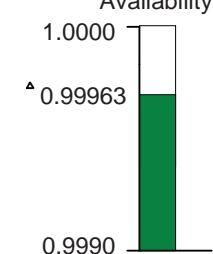
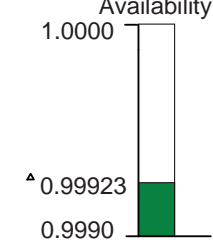
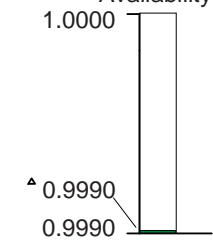
Strengths/Limitations	Availability	Energy Cost
<ul style="list-style-type: none"> + Very high efficiency + ASD has high reliability + Protects the motor against starting inrush currents + Can have alternate assignments - May require an air conditioned area or equipment house - May require an increaser gearbox 	<p style="text-align: center;">Availability</p>  <ul style="list-style-type: none"> • Advanced Pulse Width Modulated drive TMdrive-70 Adjustable Speed Drive • The only online maintenance required is changing the filters • MTBF is 127,000 hours • Repair time (MTTR) is 1.0 hour; spares are required 	<p>* TMdrive-70 ASD flow control system uses \$1,358,709 of electrical energy per year.</p>
<ul style="list-style-type: none"> + Very high efficiency + Redundant ASD has very high reliability + Protects the motor against starting inrush currents + Can have alternate assignments - May require an air conditioned area or equipment house - May require an increaser gearbox 	<p style="text-align: center;">Availability</p>  <ul style="list-style-type: none"> • Individual LCI channels can be isolated and repaired at any time while the other 2 channels continue to drive the motor • MTBF is 175,000 hours • Repair time (MTTR) is 1.1 hours; spares are required 	<p>* LCI ASD flow control system uses \$1,346,604 of electrical energy per year, the basis for cost comparison.</p>
<ul style="list-style-type: none"> + Valve is very reliable + Valve is fast acting for good flow control + Valve is compact - Large energy loss in the throttling valve - Valve requires frequent maintenance - May require an increaser gearbox 	<p style="text-align: center;">Availability</p>  <ul style="list-style-type: none"> • Routine maintenance such as tightening packing can be done on line • Control valve is down for between 1 to 7 days if it fails and there is no spare estimate MTTR is 96 hours • MTBF approx 260,000 hours • Spare valve required 	<p>* Valve flow control system uses \$1,654,388 of electrical energy per year.</p> <p>This is \$308,000 more than the electric adjustable speed drive.</p>
<ul style="list-style-type: none"> + Can adjust speed well above and below the motor speed + Hydraulic transmission is reliable - Very low efficiency at lower speeds - Dedicated to motor; no redundancy - Repair is a lengthy procedure 	<p style="text-align: center;">Availability</p>  <ul style="list-style-type: none"> • Maintenance intervals up to 80,000 hours • Hydraulic transmission is down for as much as 84 hours (3 1/2 days) if a failure occurs (published literature) • MTBF is 110,000 hours 	<p>*Hydraulic gearbox flow control uses \$1,416,492 of electrical energy per year.</p> <p>This is \$70,000 more than the electric adjustable speed drive.</p>
<ul style="list-style-type: none"> + Can run at high speeds so gearbox is not required - Gas turbine requires frequent maintenance - Dedicated to motor, no redundancy - Gas turbine can produce air pollution and noise 	<p style="text-align: center;">Availability</p>  <ul style="list-style-type: none"> • Gas turbine requires a month downtime every 3 years; MTBF is 8,000 hours. • Liquid fuel turbine requires 8 hours downtime every year • Steam turbine is taken down every 4 years • Assume MTTR is 8 hours 	<p>* Gas turbine flow control uses \$1,963,084 of gas energy per year.</p> <p>This is \$616,000 more than the electric adjustable speed drive.</p>

Note: Efficiency of mechanical devices decreases at lower speeds, but electric drive efficiency is constant over the operating range, so savings using ASD increase as speeds are lowered; see page 31.

Mean Time To Repair (MTTR) and Mean Time Between Failures (MTBF) are based on plant operating experience.

$$\Delta \text{Availability} = \frac{\text{MTBF}}{\text{MTBF} + \text{MTTR}}$$

Drive Applications for Compressors & Pumps

Variable speed drives are often used to control the speed of compressors and pumps in the oil and gas industry. Most of the VSD applications control flow through pipelines and control the input flow to large process units. The following seven pages describe five typical applications and present the reasons why an electrical solution was chosen.

1. Refinery compressors
2. Offshore platform pumps
3. Gas pipeline compressors
4. Gearless high-speed compressor drive
5. Liquid natural gas plant compressors

Application 1. Refinery Compressors

A large refinery used gas turbines to drive two compressors. The turbines generated nitrogen oxides (NOX), noise pollution, and required more maintenance than electric motor drives. The refinery evaluated electric motors and hydraulic variable speed gearboxes, vs. electric drives, and chose an electric drive as the best solution.



The refinery's new approach was to:

- Replace the two gas turbines with two electric motors of 30,000 hp, and use one LCI adjustable speed drive for motor starting and speed control.
- Use gear boxes to increase the speed input to the compressors from the 1,800 rpm motor speed.
- Use the adjustable speed drive to start one motor and synchronize it with the 13.8 kV bus.
- Employ switchgear to put this motor across the line and run the compressor at constant speed.
- Use the adjustable speed drive to start the second motor and continuously vary the speed of the second compressor to obtain the flow required by the process.

Advantages of the Drive System

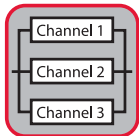

Very High Reliability – The LCI has built-in channel and component redundancy allowing operation with a single failure without any reduction in power output. Consisting of three parallel active channels, the LCI can operate on two channels while the third is being repaired. This is a TMR system with no voting. See next page.



Eliminate Air & Noise Pollution – Gas turbine exhaust NOX and noise are avoided completely, producing an environmentally-friendly installation. The electrical drive system, therefore, does not present problems meeting federal and state air and noise pollution limits.



Energy Savings – The LCI provides higher energy efficiency than either gas turbines or hydraulic variable speed drives. In addition, the synchronous motors have 17% higher efficiency than the turbines they replace.



Increased run time compared to turbine – Electric drives and AC motors require much less maintenance and down time than gas turbines. Drive availability is the highest of all adjustable speed choices; for this application is 0.999994.

Adjustable Speed Drive System One-Line Diagram

The LCI (Load Commutated Inverter) was selected for this drive application. It is a medium voltage drive and operates at 4.16 kV. Transformers drop the voltage from 13.8 kV, and after the drive, transformers increase the voltage to 13.8 kV to supply the motors. The drive has two levels of redundancy as shown in the diagram.

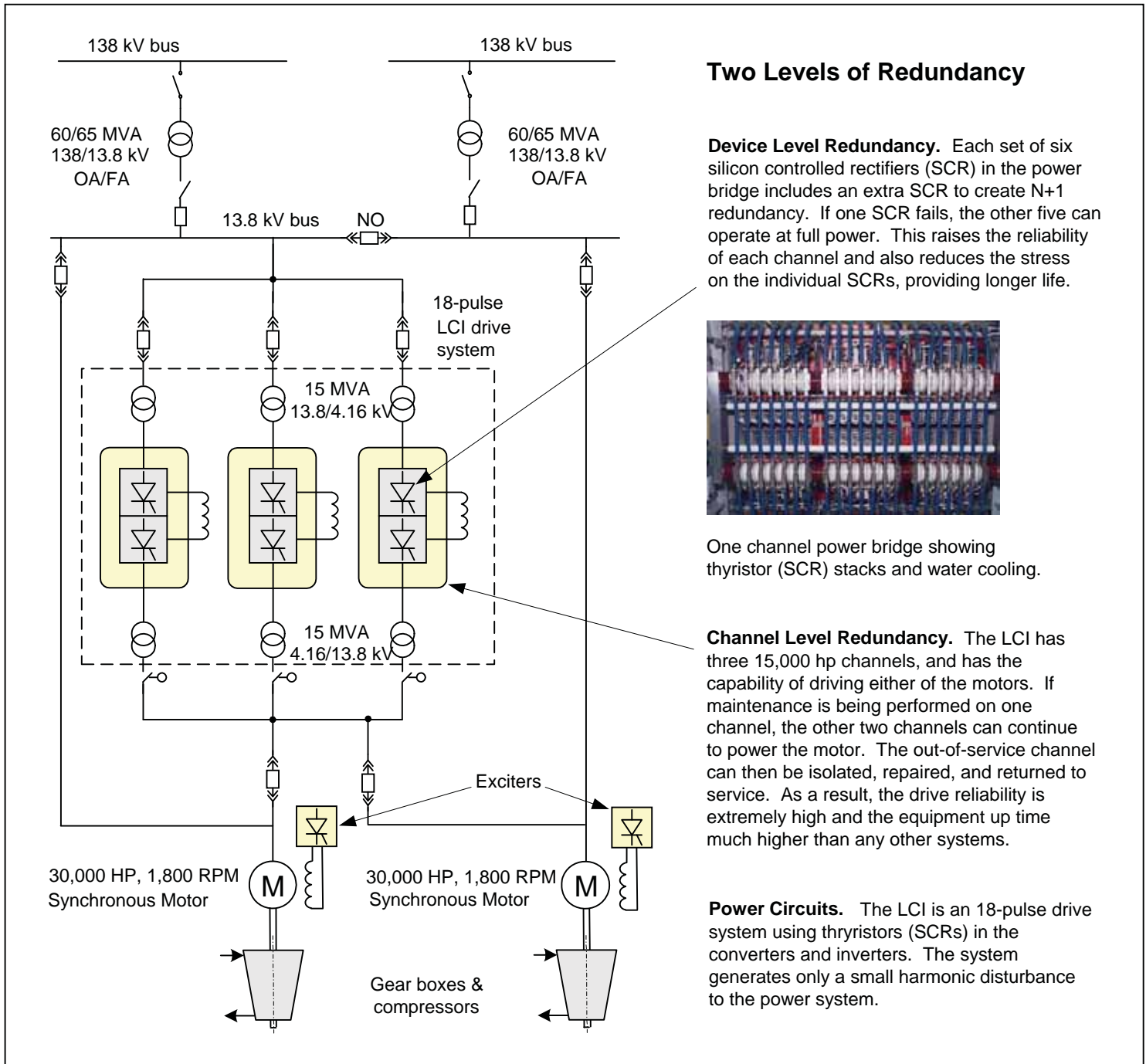

Two Levels of Redundancy

Device Level Redundancy. Each set of six silicon controlled rectifiers (SCR) in the power bridge includes an extra SCR to create N+1 redundancy. If one SCR fails, the other five can operate at full power. This raises the reliability of each channel and also reduces the stress on the individual SCRs, providing longer life.



One channel power bridge showing thyristor (SCR) stacks and water cooling.

Channel Level Redundancy. The LCI has three 15,000 hp channels, and has the capability of driving either of the motors. If maintenance is being performed on one channel, the other two channels can continue to power the motor. The out-of-service channel can then be isolated, repaired, and returned to service. As a result, the drive reliability is extremely high and the equipment up time much higher than any other systems.

Power Circuits. The LCI is an 18-pulse drive system using thyristors (SCRs) in the converters and inverters. The system generates only a small harmonic disturbance to the power system.

The two levels of redundancy illustrated above provide a 20-year system Mean Time Between Failures (MTBF) and excellent up-time with availability of 0.999994.

Application 2. Offshore Platform Pumps

Five production pumps on this offshore platform feed oil into a pipeline delivering the product to onshore facilities. Three of the 2,250 hp pumps were under control of variable speed drives to adjust the total flow to demand, and the other two were on fixed speed. The original drives were obsolete and spare parts were difficult to obtain. In addition, the older drives required power factor correction and power line filters to keep the power clean. These filters were very noisy for employees working in the equipment room for long periods.



The oil production company wanted to:

- Replace the old drives with new maintainable drives.
- Obtain high drive reliability
- Obtain better system power factor without the use of correction.
- Eliminate the noisy power line filters by using drives with inherent low harmonic distortion.
- Have the ability to perform synchronous bypass.
- Reduce the component count to increase reliability and reduce maintenance.

In making its selection for the new drives, the company regarded experienced, local service support from the New Orleans office as important. Throughout the process, the TMEiC engineering office in Virginia provided strong application support.

The first of the three old drives was replaced with a Dura-Bilt5i MV. After evaluation, a second Dura-Bilt was installed on the second pump. Each drive is equipped with the components for synchronous bypass in the future, although the actual bypass contactors were not initially included. A power study performed by TMEiC showed that the remaining old drive could operate without any filters since it represents a small portion of the load on the platform.

Benefits of the Dura-Bilt5i MV Pump System

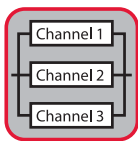

High Reliability – Advanced design including use of medium voltage Insulated Gate Bipolar Transistors (IGBTs), oil-filled capacitors, a built-in copper wound transformer, and surge and transient protection creates a drive with high reliability.

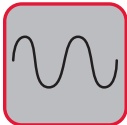

Low Harmonic Distortion – The 24-pulse rectifier’s low harmonic impact of less than 1.5% distortion gives clean operation without the use of filters, allowing the original filters to be disconnected.

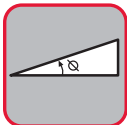

High Power Factor – The new system has a very good power factor of better than 0.95 and does not require any external power factor correction equipment.

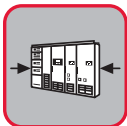

Compact Drive – The Dura-Bilt drive system fits in a smaller space than the original system because the transformer is integrated into the cabinet and the heat pipe cooling allows a very compact drive.

Pump System One-Line Diagram

In this diagram, Drive 1 is shown with a synchronous bypass option, which can be added in the future. This option will allow the drive to:

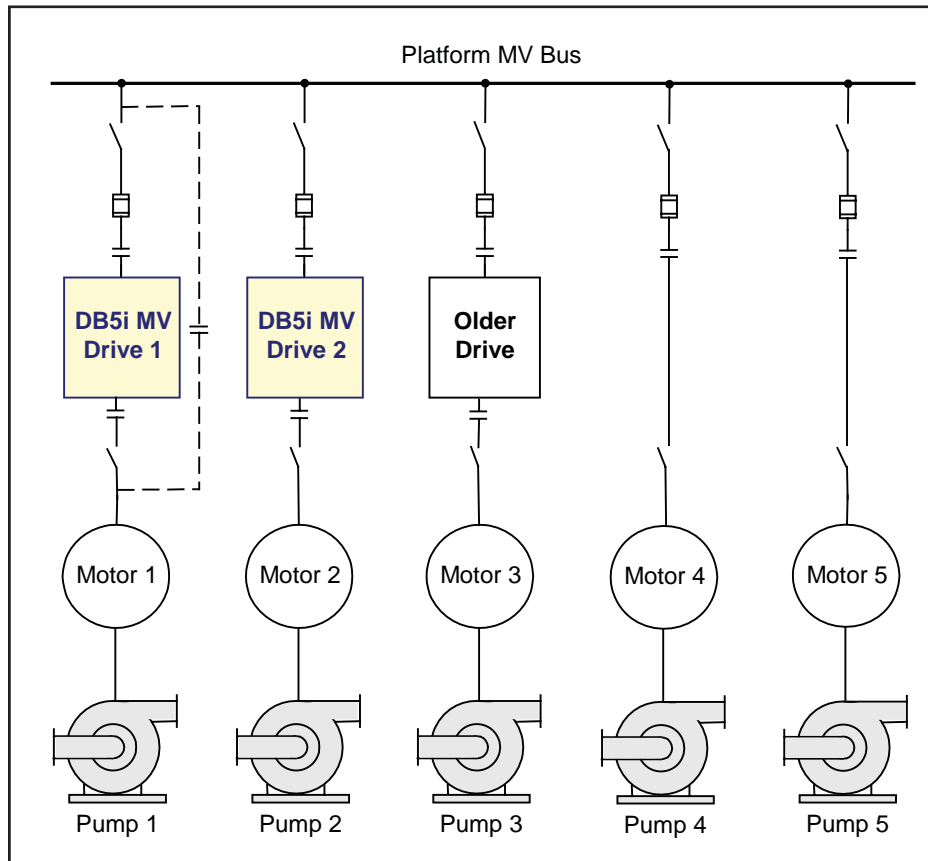

- Start Motor 1 with low current inrush.
- Bring the motor up to synchronous speed.
- Synchronize the motor with the supply bus.
- Put the motor across the line and disconnect the drive from the supply.
- Allow Drive 2 to control Pump 2 flow as required by the flow demand.

This configuration allows Motor 1 to run at full speed without the heat losses in the drive. The synchronous option can be extended to the second drive if required.

Future Improvements

The customer has the option in the future to retire the last old drive and install contactors on all motors and the two drives. With appropriate PLC control logic, the system will allow either Dura-Bilt to start and run any of the five motors, and put them across the line.

This future system improvement will provide:

- The maximum flexibility to operate the pumps under a wide range of situations.
- Soft starting available for all motors to minimize system impact and deterioration of the windings caused by inrush current.
- Reduction in the impact of drive downtime since no motor is dedicated to any drive.



Application 3. Gas Pipeline Compressors

The remote gas pipeline station used two compressors in series, driven by internal combustion engines. With this arrangement, non-optimal flow often wasted energy, and fixed pumping steps provided poor pipeline flow control. The pipeline company sought a new motor and flow control system which would:



Induction Motor and Gearbox
(compressor located on the other side of wall)

- Be responsive to fast changes in load.
- Reduce energy usage.
- Increase reliability.
- Reduce maintenance costs.
- Reduce the heat load in the building.
- Keep the existing induction motors and speed increasing gearboxes.
- Produce clean electrical power with low harmonics.

After reviewing alternatives, the company decided to replace the two existing internal combustion engines with two medium voltage variable speed drives and motors to match the pressure and flow needs of the pipeline.



The new system uses two Dura-Bilt5i MV drives connected to induction motors. These motors drive the compressors through gear boxes. To house the drives, a completely preassembled, air-conditioned power house was selected.

Benefits of the Dura-Bilt5i MV Compressor Drive System

The system meets all of the customer's requirements. In particular, the system benefits include:



Cost Savings – The savings, including reduced energy usage costs and reduced maintenance, provide a short payback on the drive system investment. On a system like this, the payback can be three years or less.

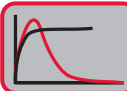

Better Flow Control – The compressor operating point can be changed quickly in response to changing pipeline conditions resulting in improved flow control and reduced energy waste.



Fast Installation – System installation was fast using the pre-assembled power house, and startup was fast because the equipment in the power house was pre-tested.

Drive System Technical Details

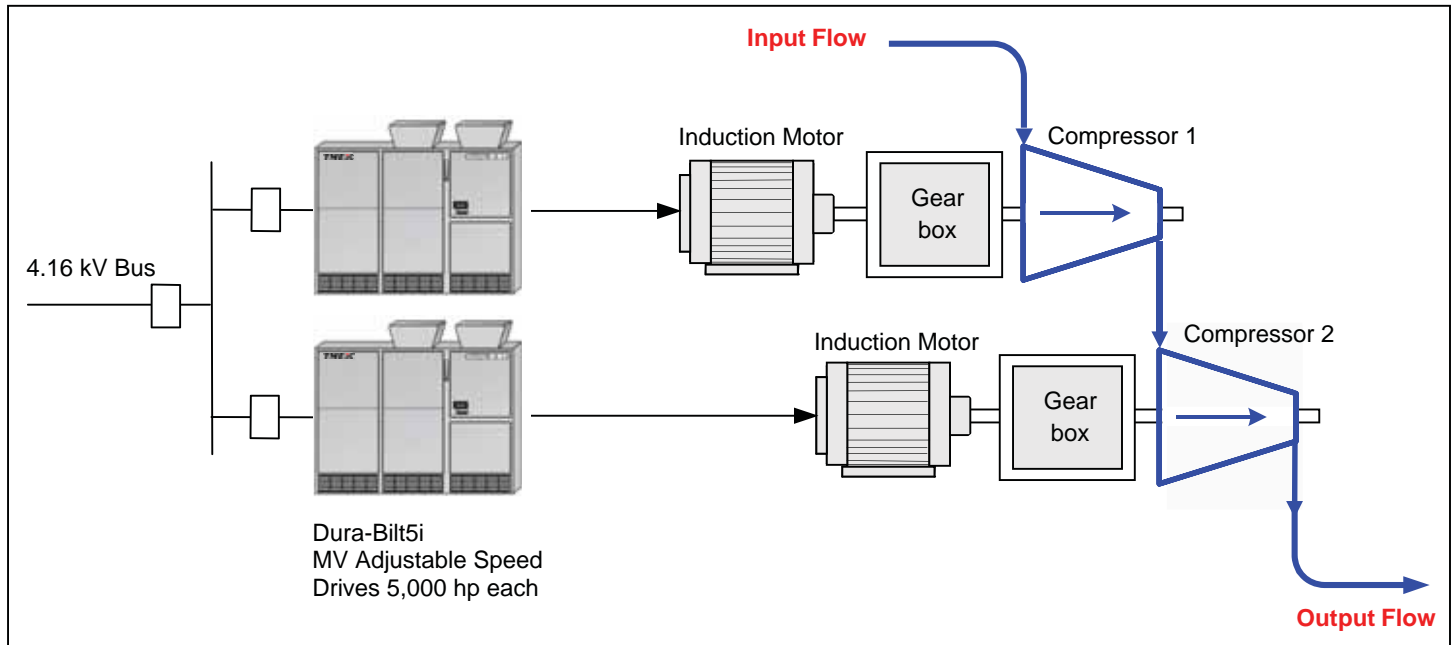

Drives:

- Two Dura-Bilt5i MV drives
- 4.16 kV rating
- 5,000 hp each

Drive Rectifiers:

- 24-pulse diode converter
- Less than half the lowest IEEE 519 standard harmonic current distortion limit

Drive Inverters:

- Five-level neutral point clamped PWM inverter
- 3,300 Volt IGBTs
- Heat pipe cooling

Actual Motor Operating Conditions:

- 4,500 hp
- 49 Hz supply from drive
- 1,443 rpm output

Modular Design of the Dura-Bilt5i MV

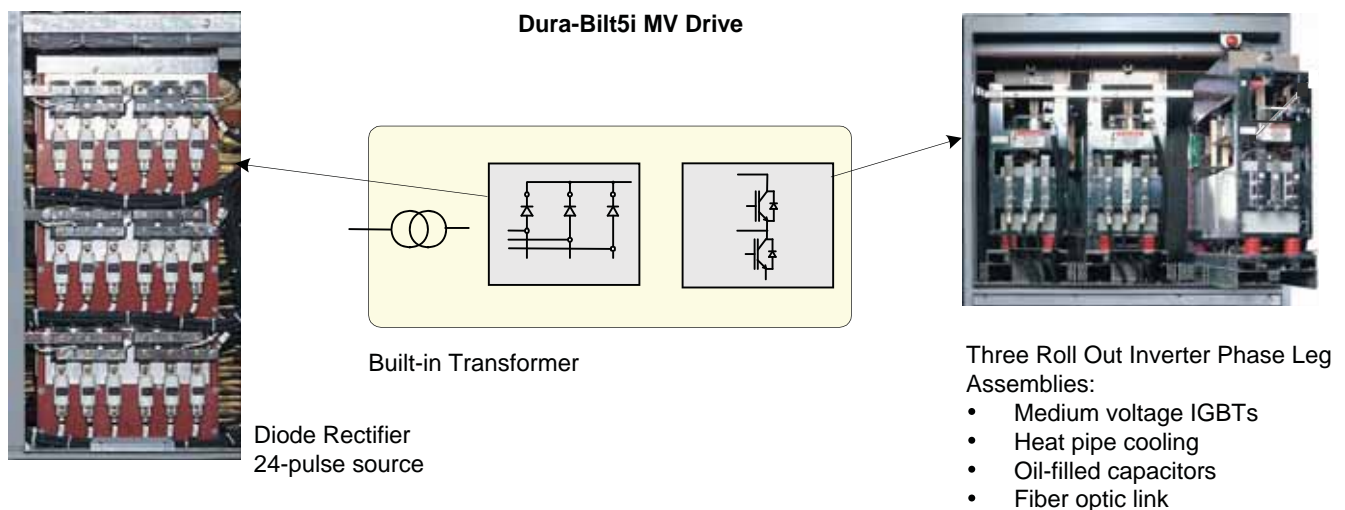

Application 4. High-Speed Motor Drives Gas Compressors

Conventional gas pipeline compressors are driven directly by gas turbines. However, the turbines have high operating and maintenance costs and generate nitrogen oxides (NOx) and CO₂. This gas pipeline application uses the TMdrive-80 VSD coupled to a high-speed synchronous

motor to drive the gas compressors. With motor speeds up to 8,200 rpm, no gearbox is required. The compressor stations on the gas pipeline use this TMEiC all-electric variable speed drive system as illustrated below.

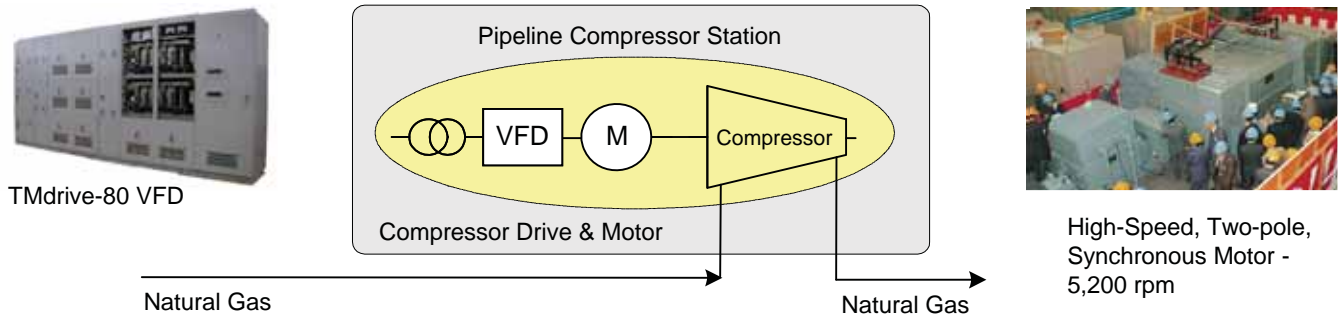

The TMdrive-80 high-speed GCT (Gate Commutated Turn-off Thyristor) inverter has the world's largest capacity. The GCT can operate at elevated speeds and be applied to voltages of 3.3 kV. The TMdrive-80 configuration perfectly fits large gas compressor applications.

Advantages of a High-Speed Drive System



High Reliability and Availability – The TMdrive-80 and synchronous motor have a much higher reliability than the gas turbine, based on field experience. In addition, repair time is shorter, so system availability is excellent.



Air & Noise Pollution Eliminated – Gas turbine exhaust NOx and CO₂ and noise are avoided completely, producing an environmentally-friendly installation.



Low Operating & Maintenance Costs – The TMdrive-80 and synchronous motor combination has a much higher energy efficiency than the gas turbine. In addition, maintenance and repair costs are significantly reduced.

Application 5. LNG Plants

Electric drive systems power the compressors in liquid natural gas (LNG) plants. These compressors are very large in size and use synchronous motors running at 3,600 rpm.

The drive used is the TMdrive-XL85, which employs GCT inverters at 7.6 kV. This drive can be expanded by adding parallel channels to obtain power levels up to 90 MW. Refer to the section on Drives for more information on the TMdrive-XL85.

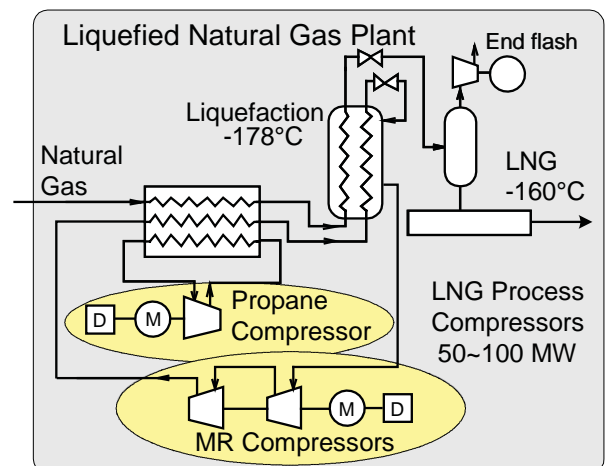

Project Engineering



TMEIC's Engineering Drive Team in Virginia

Experienced Drive Engineering Team

The drive engineering team is experienced in the oil and gas industry and gained its experience working in the plants with technicians and mechanical suppliers. This engineering background, coupled with state-of-the-art technology, enables TMEIC to consistently meet the demanding requirements of the industry.

Experienced drive engineers jointly define the MV equipment and control strategy with your engineers and the OEM. This is followed by detailed design of the system, control logic, and configuration of the drives.

Comprehensive Factory Test Minimizes Risk

We understand that delay in commissioning is very expensive, so we take steps to hold our startup schedule:

- Complete factory test including applying power to the bridges, exercising the control with process simulation, and checking test modes.
- The local commissioning engineers are part of the project team, allowing a seamless transition from the factory to your plant.
- For complex applications, factory control engineers organize the factory test and assist with the commissioning.

Local Commissioning Team Ensures Knowledgeable Ongoing Service

Our field service organization is broad and deep with extensive experience in the industry providing you with a strong local service presence for startup and ongoing service work, both in North America and overseas.

We Engineer the Medium Voltage Power System

TMEiC application engineers design the power system from the medium voltage switchgear to the adjustable speed drive and motor. The critical engineering process for a successful installation is illustrated in the chart (top of next page) and detailed in this Project Engineering section. Icons indicate where the various teams of engineers in the factory and field service are involved in the project.

A typical MV power system is shown below. TMEiC application engineers size and select all the equipment for the optimal drive solution.

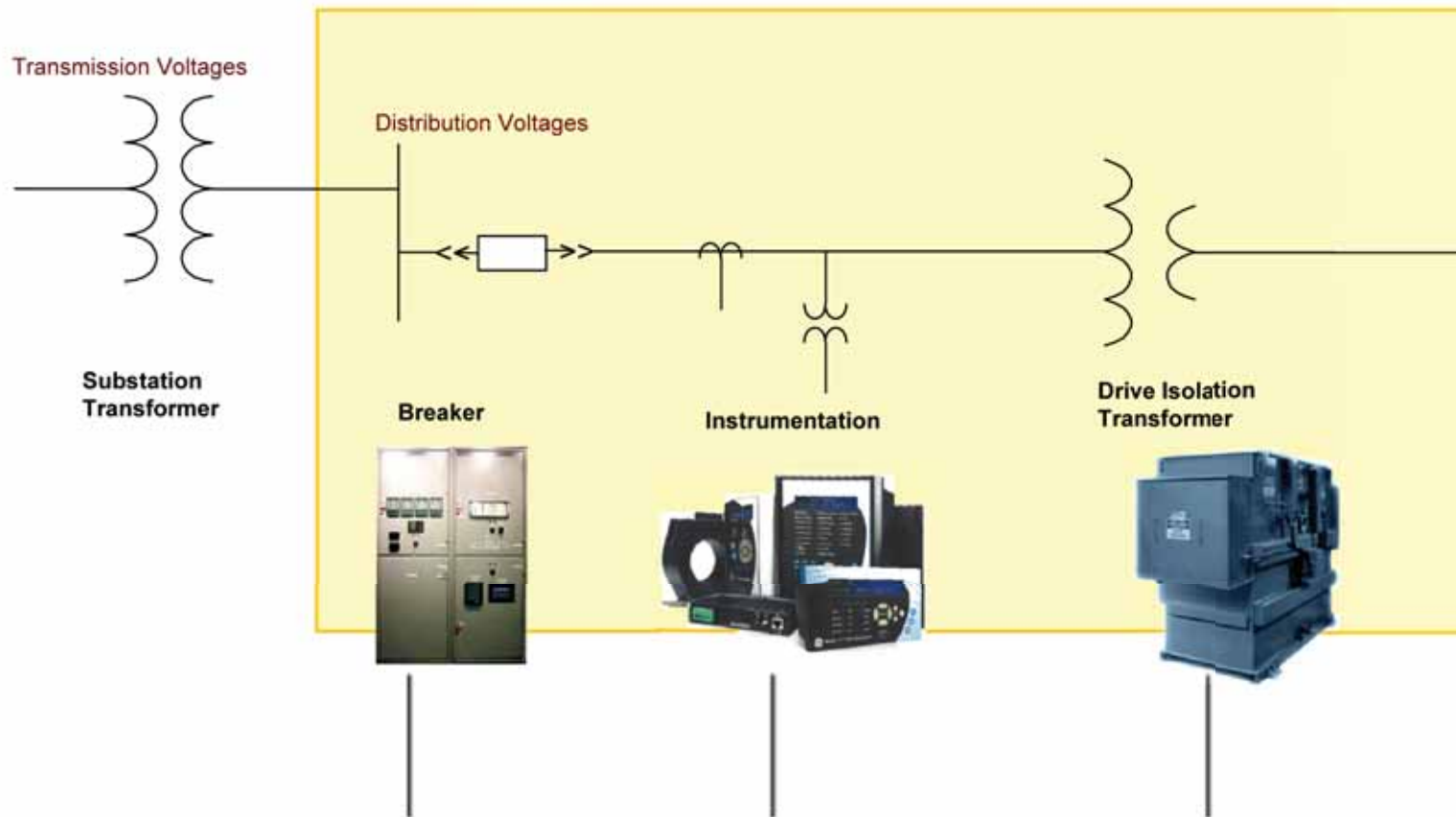

MV switchgear is selected for the application considering:

- The type, such as vacuum or SF6
- The size for the current and voltage
- The CTs, PTs, and protective relays to operate the breaker
- The enclosure for outdoor or indoor
- The environment such as temperature and humidity

Instrumentation for equipment metering, monitoring, protection and control is selected, including:

- Amp transducer and ammeter
- Watt and Watt-hour transducers
- Phase CTs and phase overcurrent relay
- Ground sensor CT and relay
- Power quality monitor

Drive isolation, input and output, transformers are selected for the application considering:

- The type, such as dry or liquid filled
- Size for the kVA and voltage
- Cooling if required
- The enclosure for outdoor or indoor
- The environment such as temperature and humidity
- Special drive requirements

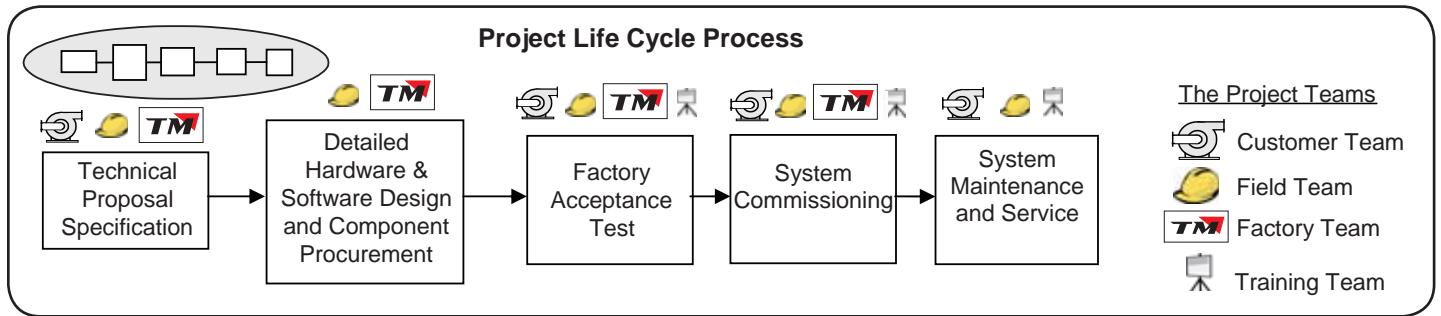

Drive Utilization Voltage



Adjustable Speed Drive



Heat Exchanger



Motor



Selection of the best adjustable speed drive for the application based on:

- Continuous and overload torque and power requirements
- Type of load, including constant or variable torque or regenerative
- Drive and motor voltage
- Power system compatibility
- Overall efficiency of the ASD and motor combination
- Harmonic analysis

Selection of optional drive associated equipment such as:

- Reactor for use with an LCI
- Heat exchangers if required
- Air conditioned equipment house if required
- Switchgear if motor is to be synchronized with the line
- PLC for logic control, for example synchronizing multiple motors with the supply for soft start capability

Selection of the motor and associated equipment including:

- Induction or synchronous motor
- Motor size including power, torque, voltage, current, and speed
- Selection of the exciter if a synchronous motor is used
- Required motor protection devices
- Optional tachometer for special applications
- Torsional analysis

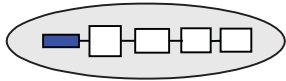

Technical Proposal Specification

TMEiC Assists in the Project Planning

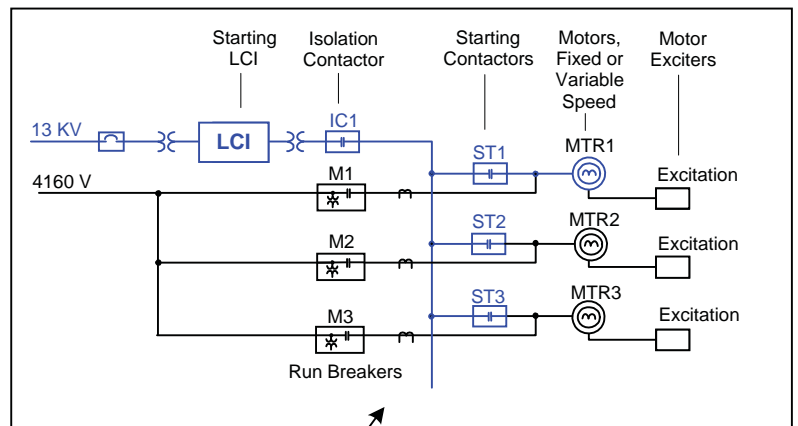
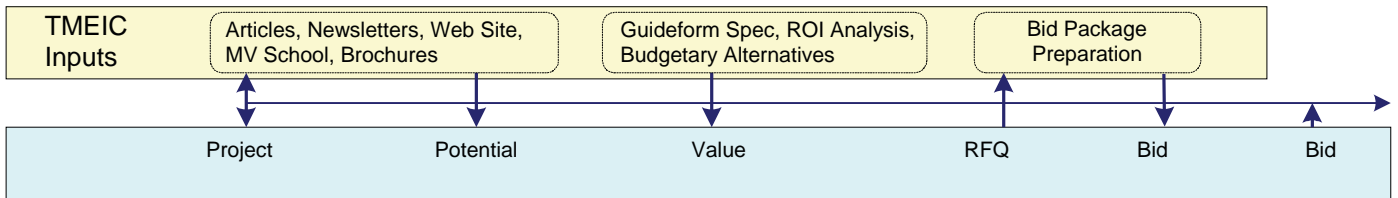

System architecture illustration

Detailed description of equipment in proposal

During all phases of your project planning, TMEiC assists by supplying information, training, guide-form specifications, and general advice. Experienced MV drive application engineers prepare a technical proposal that includes:

- Customized system architecture for your project.
- Detailed equipment specifications for the drives, excitors, transformers, switchgear, and housings.
- Thorough description of the PLC control functions, including logic for synchronizing and de-synchronizing the motors.
- Formal bid documentation.

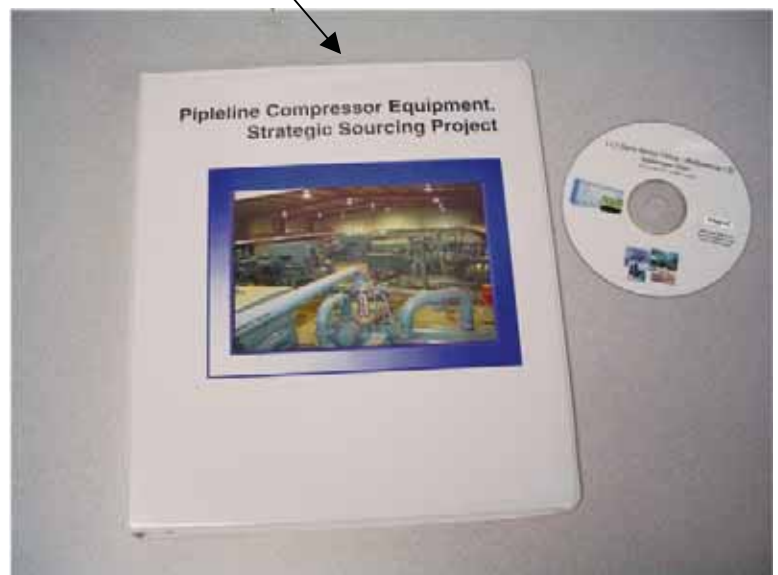

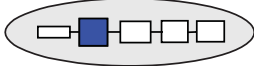

Detailed Hardware/Software Design & Procurement

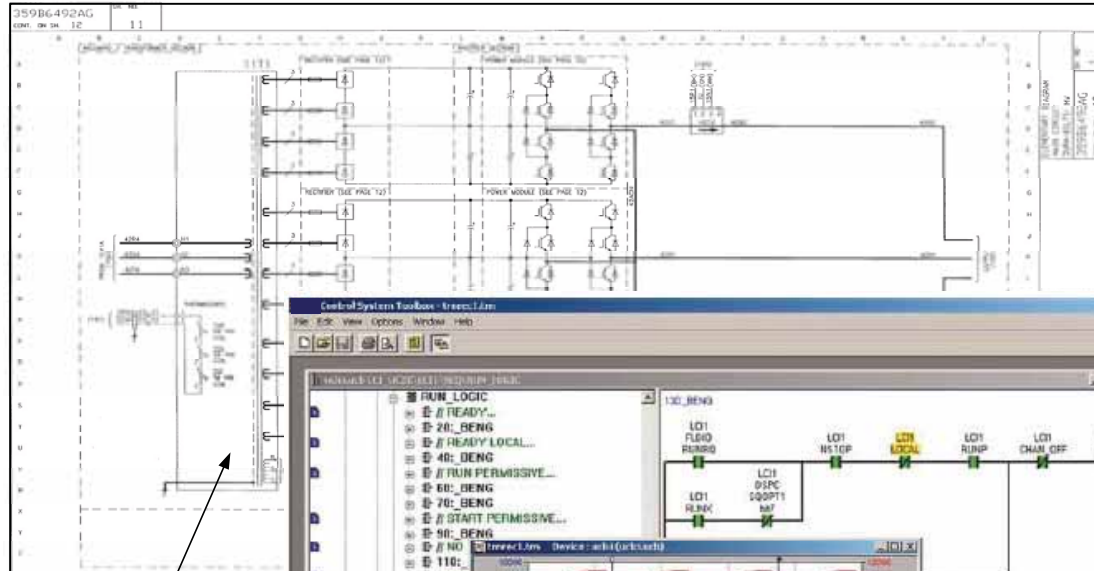

Electrical and mechanical prints

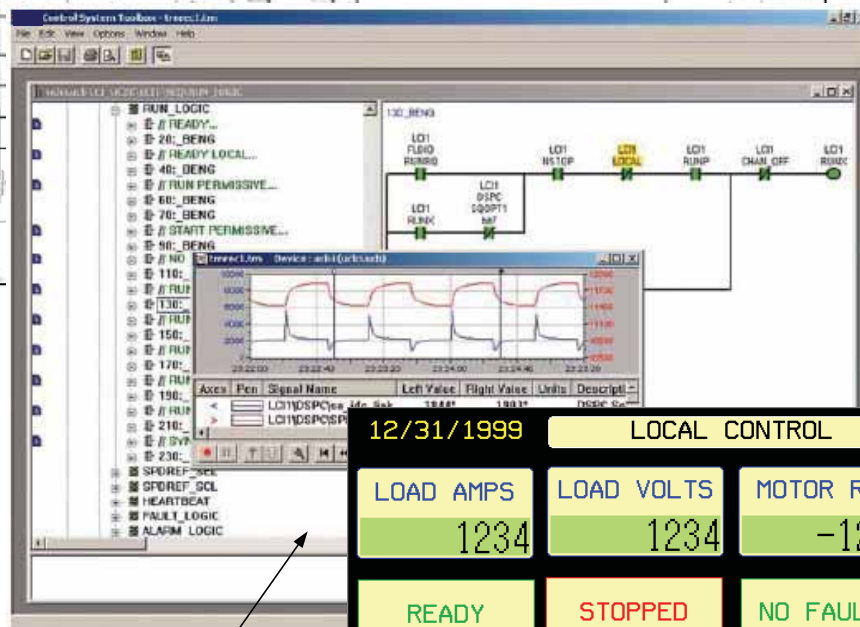

Control logic and drive configuration

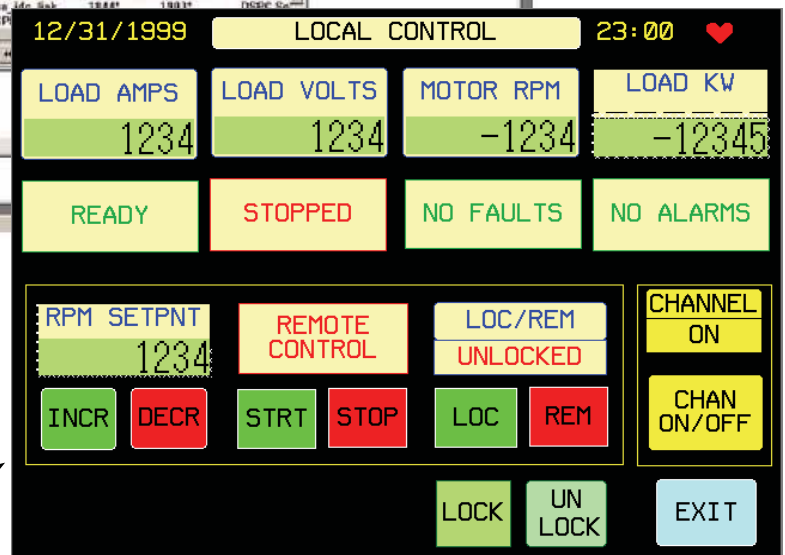

HMI screen design

Based on the proposal specification, the project engineering team proceeds with four main tasks:

- Control Software Design.** Control engineers configure the drives and PLC controller logic, if a PLC is required for the application. The illustration above shows a typical toolbox logic function diagram in Relay Ladder Diagram format. The TMdrive-Navigator is used for drive configuration, tuning, sequencing, and drive diagnostics.
- Optional HMI Screen Design.** Interface screens for maintenance and drive control are configured using the touch panel engineering tools. These screens provide real-time drive data and operator interaction.
- Hardware Design.** All equipment is specified per the project requirements, and a complete set of elementary diagrams, layout, and outline drawings is created.
- Component Procurement.** We work with our parent companies to source the most cost effective system components for your application.

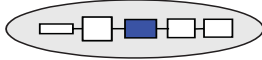

TMEiC understands the importance of a thorough system test. Our engineering team conducts a comprehensive factory test before shipment. These tests consist of:

- Complete staging of the system with the drive, controller, I/O, and communication networks.
- 460 V gate test of all power semiconductors.
- Test of the bridges at high current connected to an external load.
- Validation of current and voltage feedbacks.
- Validation of all I/O interfaces, and the touch panel.
- Validation of the drive test modes.
- Test of the cooling system.



LCI Control Validation in the Engineering Lab

Toolbox software for Drive and Logic Configuration



Simulation Software

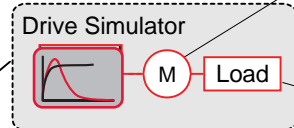

Digital Motor Simulator

Digital Load Simulator

Optional PLC with Logic and Simulation of multiple Bypass Contactors

Logic for Soft Start and Synchronization of Multiple Motors for example

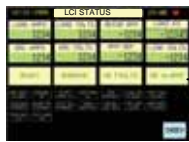

Touch Panel Display & Control

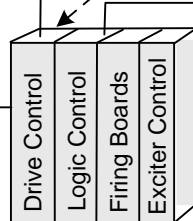

LCI Controller

Diagram of LCI Drive Test Setup

Validation of the optional LAN-DCS link and PLC sequencing and logic is done in the engineering lab using a simulated drive, motor, and load. Using the computer-simulated equipment, the PLC is run through its sequencing and the resulting outputs validated.

Note that logic for synchronizing a single motor can be included in the LCI controller so a PLC is not required.

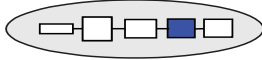

System Commissioning

In the commissioning phase, the TMEIC team includes the field engineers you know and trust, alongside the engineer who designed and tested the system. This overlap of teams between engineering design and the site ensures a smooth and on-schedule startup.

The TMEIC service engineer, who is responsible for startup and commissioning, and for any future service required at the site, is part of the project team and participates in the factory system test to become familiar with the system. Commissioning is supported by TMEIC design and service engineers.



Drive Training at our Training Center or in Your Facility



Customer engineers, maintenance and operations personnel are trained on the drives and control system at the TMEIC Training Center in Virginia. This world-class facility includes large classrooms and fully-equipped training labs.

Classroom and hands-on training consists of 50% class time and 50% hands-on lab time. Topics include:

- Overview of the drive system
- Function of the main assemblies
- Technical details of the components
- Drive and control system tools
- System diagnostics and service

As an alternative to the standard factory training in Virginia, TMEIC can offer a course tailored to your project and held at your location. In this case, a project engineer trains your operators, maintenance technicians and engineers in your facility.

Complete and Detailed Drive System Documentation

Along with the hardware and software, TMEIC delivers complete system documentation:

- An electronic instruction book with all the prints on CD with a hyperlink index
- System configuration on CD
- Detailed system manual
- Recommended wiring and grounding procedures
- Renewal parts list
- Standard third-party vendor documentation

At the end of the project, the drawings are updated to reflect the final changes.



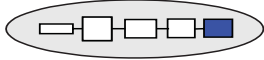

System Maintenance & Service

Global Customer Support Network

Comprehensive technical service is provided by our Customer Support Organization, staffed by TMEiC service engineers with offices and spare parts depots across the globe.

In North and South America

Customers are supported by the TMEiC Corporation service personnel, design engineers and Spare Parts Depot in Virginia, and the TMEiC Factory in Japan.

In Europe

TMEiC service engineers service all drive systems in Europe, supported by the European TMEiC Spare Parts Depot.

In Asia and the Pacific Rim

TMEiC services drive systems throughout China, India and the Pacific Rim, supported by multiple Field Engineers, Spare Parts Depots, and the TMEiC factory in Japan.

Remote Drive Diagnostics

TMEiC Corporation supports drive customers through the **Remote Connectivity Module (RCM)**, a remote diagnostic service link with the TMEiC design and service engineers in Roanoke, Virginia. The RCM enables seamless integration between your drives and our engineers.

Remote System Diagnostics

TMEiC's remote system diagnostics tool offers a quick path to problem resolution. System faults are automatically identified, and provide an integrated view of product, process and system information. TMEiC design and service engineers in Roanoke, Virginia, can analyze the data and provide steps for resolution.

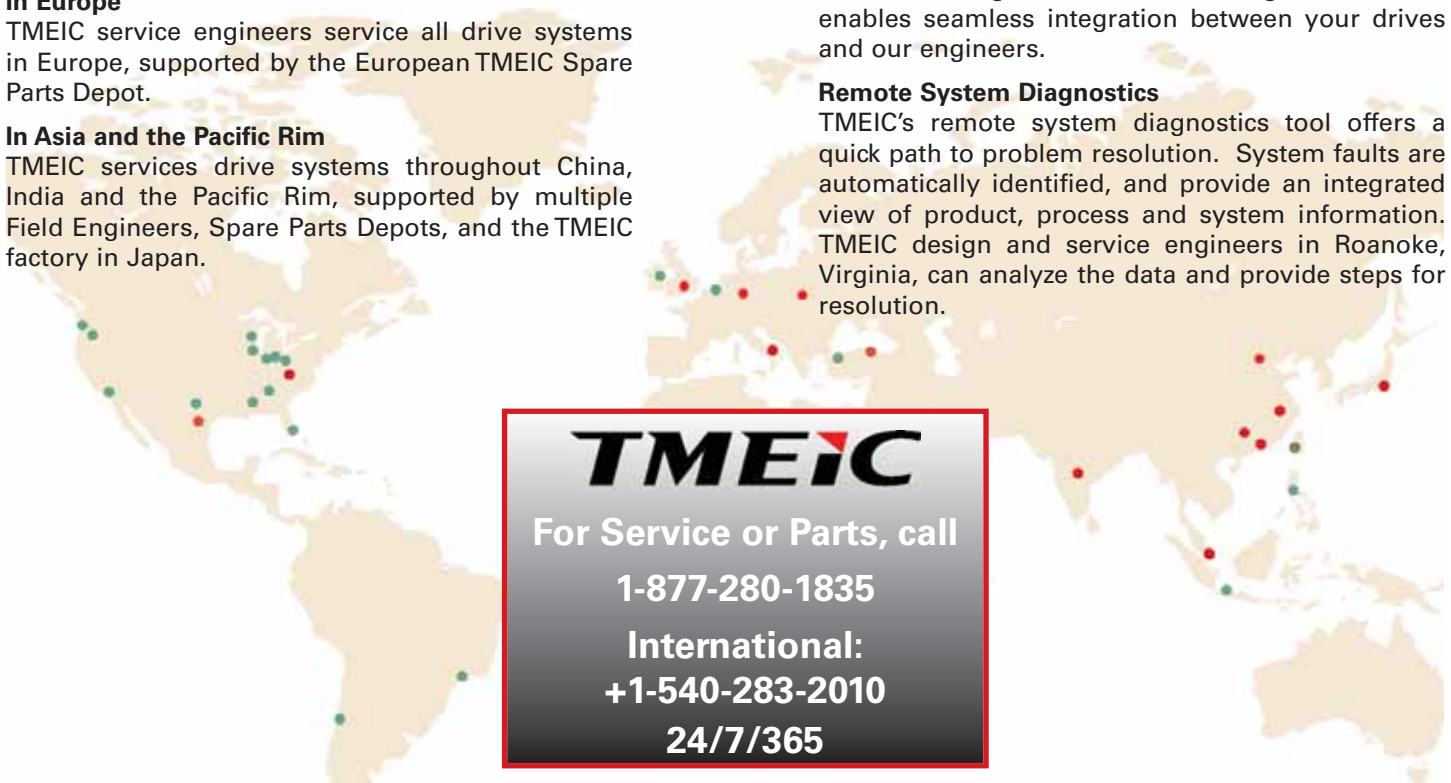



For Service or Parts, call
1-877-280-1835
International:
+1-540-283-2010
24/7/365

Remote Diagnostic Service reduces Mean Time To Repair (MTTR)

Remote diagnostic service offers protection for your investment, by reducing downtime, lowering repair costs and providing peace of mind. Remote diagnostics requires an internet connection between your plant and TMEiC Corporation for retrieval of fault logs and files to diagnose drive or system issues.

Features	Benefits
<ul style="list-style-type: none"> Reduced downtime and Mean-Time-to-Repair 	<p>Quick support saves thousands of \$ in lost production TMEiC engineers can quickly connect to the drive and diagnose many issues in a matter of minutes.</p>
<ul style="list-style-type: none"> Secured connection 	<p>Customer-controlled access All remote activity is conducted with permission of the customer. Drive start/stop is not permitted remotely.</p>
<ul style="list-style-type: none"> Fault Upload Utility 	<p>Proprietary Fault Upload Software Historical drive faults are identified; TMEiC design and service engineers can analyze the issue resulting in the fault and provide a solution.</p>

The World's Largest Fleet of Installed MV Drives



TMdrive-70



Dura-Bilt5i MV



TMdrive-XL85

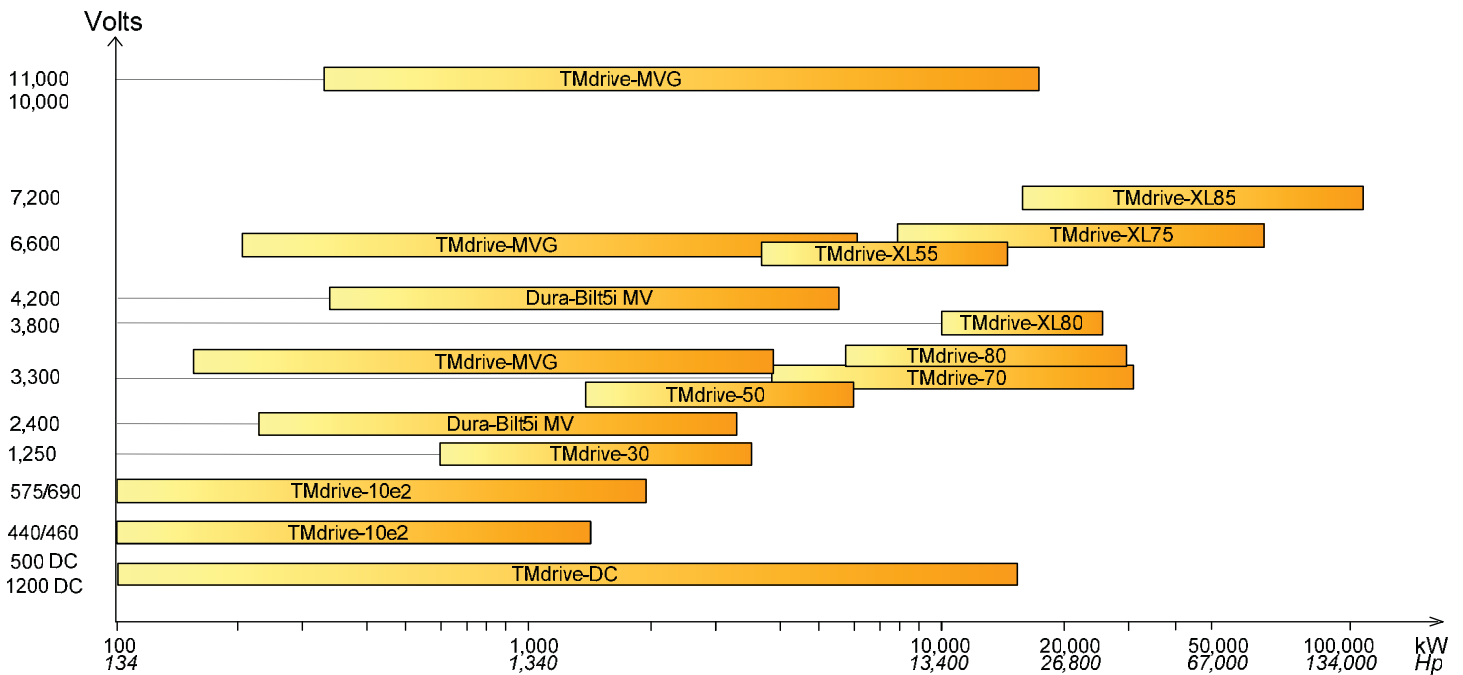

TMEIC Family of Medium Voltage AC System Drives

Largest Installed Base. Since the LCI was introduced in 1979, over 2 million hp of drives have been installed and are in service. More recently, a large number of Innovation Type G, H, and SP drives have been installed, as well as the new technology Tosvert, Dura-Bilt, and TMdrives. This represents the largest installed base of MV drives of any manufacturer.

Significant Investment in MV Technology. TMEIC's Tosvert, Dura-Bilt, and TMdrive products represent a large investment in MV drive technology, including development of semiconductor devices such as the IEGT and GCT.

The Highest Reliability. TMEIC drives provide the highest reliability based on field experience and customer satisfaction surveys.

World-class Configuration Software. The Windows-based configuration software provides configuration, tuning, sequencing, and drive diagnostics.

Large Spare Parts Stock. TMEIC's parts depots stock the line of MV drive parts and provide rapid delivery to your plant anywhere in the world.

Load Commutated Inverter (LCI) System Drive Overview

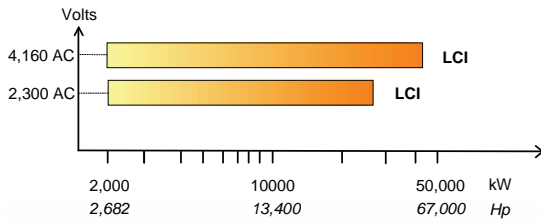

The LCI drive is ideal for any high power synchronous motor application requiring adjustable speed operation or soft starting. With an optional output transformer, the LCI can operate with any motor voltage. Motor field excitation is included as well as a synchronizing and de-synchronizing function to smoothly start large motors.

Power Converter Blocks:

- 2,300 Volt, 6-pulse source – 5,224 kW, 7,000 hp
- 2,300 Volt, 12-pulse source – 10,448 kW, 14,000 hp
- 4,160 Volt, 6-pulse source – 13,433 kW, 18,000 hp
- 4,160 Volt, 12-pulse source – 13,433 kW, 18,000 hp

LCI power converter blocks can be paralleled to deliver ratings in excess of 70,000 hp. Multi-channel (block) operation allows the opportunity for dual and triple channel redundancy for very high reliability applications.

Features

Benefits



Unique Bridge Design
Each bridge uses full voltage rated SCRs (thyristors) in an N+1 configuration

Maximize Reliability and Up-Time
N+1 redundancy insures full power output even in the event of an SCR device failure.



Highest System Efficiency
The synchronous motor and LCI combination is one of the highest efficiency drive system available.

Most Cost Effective High HP Systems
High efficiency means reduced energy consumption and lower costs over the project life.

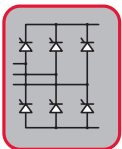

Input Configuration
The drive can be configured for 6-, 12-, or 24-pulse input.

Power System Friendly
Flexible input configuration choice allows cost effective installations for low harmonic distortion.

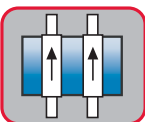

Water Cooled Technology
Fully redundant cooling system; hoses don't need to be disconnected for bridge service.

Compact, Quiet Design
Reduces and simplifies maintenance, reduces ambient noise, and saves valuable floor space.



Windows-Based Configuration & Maintenance Tools
For PC-based configuration, the toolbox features animated block diagrams and a trend window.

Faster Commissioning and Maintenance
The software configuration toolbox improves productivity in commissioning and maintenance.

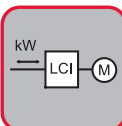

Built-In Line Regeneration
Energy in the load can feed back into the source converter and out to the MV supply.

Large Energy Savings
Load energy, which would otherwise be turned into heat, is recovered, resulting in reduced utility bills.

LCI Control Features:

- Load commutation above 10% base speed
- Sensorless speed control
- Speed control range: 10-150% of base speed with logic to prevent reverse operation
- Built-in regeneration for smooth control of loads

Cabinet Lineup:

Length - 158 in (4,000 mm) for 7,000 hp version.
 - 220 in (5,600 mm) for 18,000 hp version.
 Height - 100 in (2,500 mm) for all cabinets.
 Depth - 55 in (1,400 mm) for all cabinets.

Cooling System

In the closed-loop cooling system, coolant circulates from the pump discharge, to the heat exchanger, to the power conversion bridges, and back to the pump. Pumps can be switched over and changed without interrupting cooling.

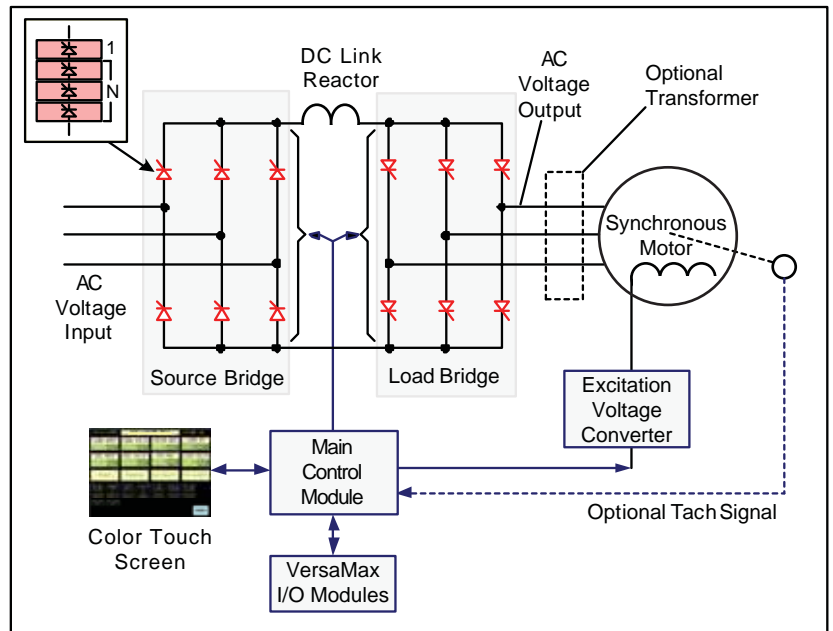

LCI Source and Load Bridge Configuration

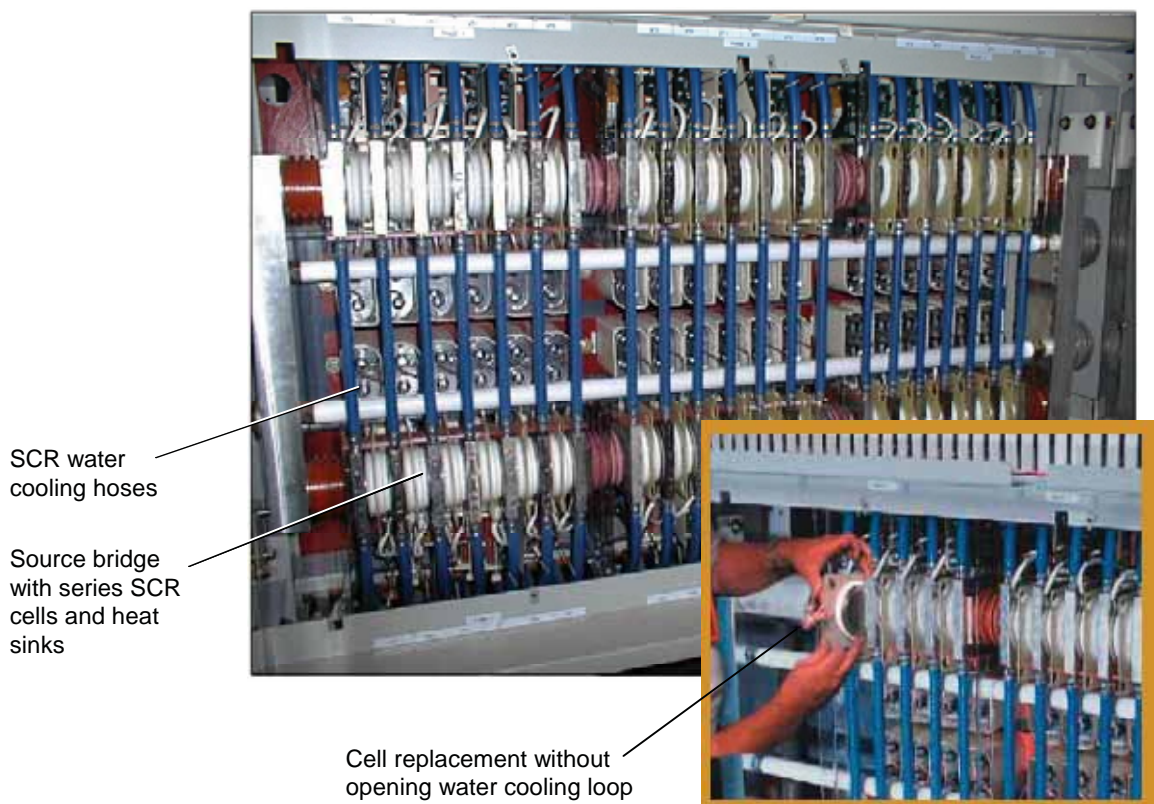

Dura-Bilt5i MV Medium Voltage PWM Drive

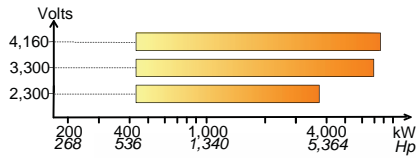

Dura-Bilt5i delivers simple operation in a robust and compact design, providing a cost effective solution for a broad range of medium voltage applications.

The Dura-Bilt5i MV delivers value through low cost of ownership and high reliability. Power levels available include:

- **2000 Series** – 2,300 Volts Out, 300 to 3,000 hp
- **3000 Series** – 3,300 Volts Out, 400 to 4,000 hp
- **4000 Series** – 4,160 Volts Out, 400 to 10,000 hp

Rugged design features for high reliability include:

- Inverter heat pipe cooling.
- Diode rectifier converter with 24-pulse circuit for low input current distortion.
- Neutral point clamped pulse width modulated inverter using medium voltage IGBTs.

Cabinet Size:	1,000 hp drive is 74 inches (1,880 mm) long Cabinet height is 104 inches (2,642 mm)
	5,500 hp drive is 222 inches (5,639 mm) long Cabinet height is 104 inches (2,642 mm)
	10,000 hp drive is 403 inches (10,237 mm) long Cabinet height is 104 inches (2,642 mm)

Features

Benefits

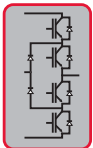

Medium Voltage IGBTs

Each inverter uses 3,300 Volt Insulated Gate Bipolar Transistors (IGBTs).

Rock Solid Reliability

High power IGBTs allow a simpler, more reliable inverter design with fewer power switches.

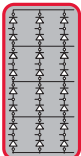

24-Pulse Converter

Each phase leg of the converter includes a 24-pulse diode rectifier.

Power System Friendly

This design exceeds the IEEE 519-1992 specification for Total Harmonic Distortion (THD) without requiring filters.



Heat Pipe Cooling Technology

Each of the three inverter legs use heat pipe cooling for the IGBTs.

Compact Quiet Design

The heat pipe cooling reduces fan noise and saves valuable floor space in your plant.



Windows-Based Configuration & Maintenance Tools

For PC-based configuration software the toolbox features:

- Animated block diagrams
- Drive tune up wizards
- Integrated trend window

Faster Commissioning and Maintenance

The software configuration toolbox improves productivity in commissioning and maintenance.

Dura-Bilt5i MV Power Bridge Technology

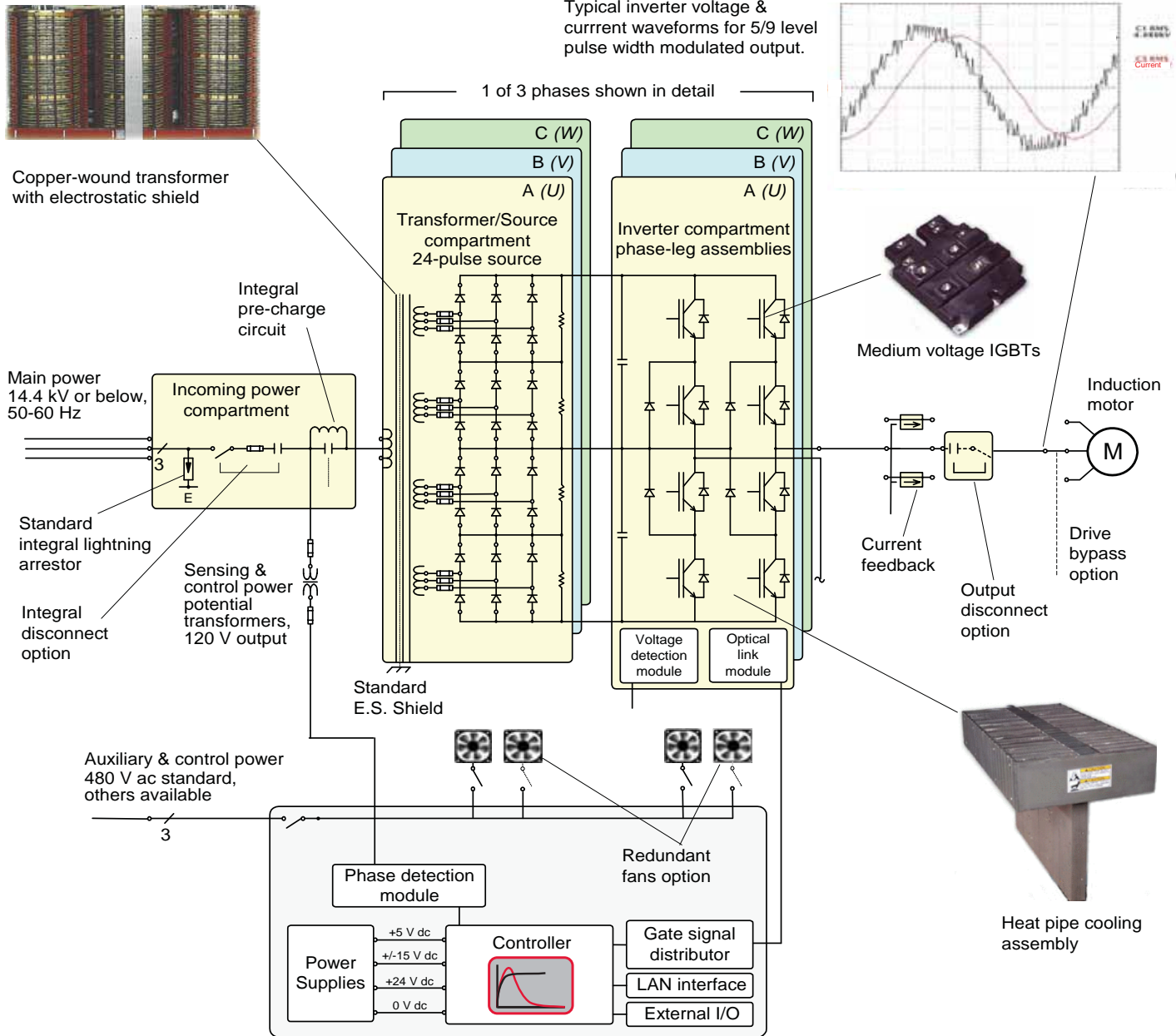

Additional Features

- Operator keypad provides real time drive data
- Integral copper wound transformer rated for 115°C rise with electrostatic shield
- Incoming power protected by lightning arrestors
- Roll out inverter phase leg assemblies
- DC bus capacitors, oil filled for long life
- Closed transfer synchronizing control
- Induction or synchronous motor
- Fuse protection on source diodes with blown fuse indication
- Operation at 0° to +40°C; up to +50°C with derating
- Speed regulation $\pm 0.01\%$ with speed sensor; $\pm 0.5\%$ without
- Field oriented vector control torque accuracy $\pm 3\%$ with temp sensor
- 3% or less motor current harmonic distortion

TMdrive-70 and TMdrive-80 Medium Voltage Drives

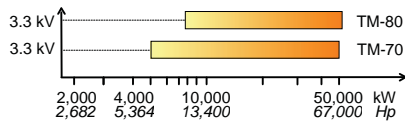

The TMdrive-70 – Designed for high-power applications

- **Frame 8000** – 3,300 Volts out, motor power 10,000 hp
- **Frame 20000** – 3,300 Volts out, motor power 26,000 hp
- **Frame 40000** – 3,300 Volts out, motor power 52,000 hp

Rugged design features for high reliability:

- Water cooled power bridge
- Converter and inverter using medium voltage Injection Enhanced Gate Transistor (IEGT) power semiconductors with high-speed switching
- Pulse Width Modulation using fixed pulse pattern control to reduce switching losses
- Neutral point clamp diodes
- Regenerative IEGT converter available

Cabinet Size:

- Frame 8000 - 126 inch (3,200 mm) long, 94 inch high.
- Frame 20000 - 220 inch (5,600 mm) long, 94 inch high.
- Frame 40000 - 252 inch (6,400 mm) long, 94 inch high, plus a second cabinet, 189 inch (4,800 mm) long.

Features

Benefits

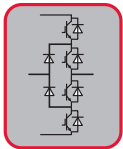

IEGT-based Converter and Inverter, TM-70
Both the converter and inverter use state-of-the-art technology and design based on the Injection Enhanced Gate Transistor (IEGT).

Drive provides Near Unity Power Factor to the Load

The IEGT phase leg assemblies provide power at near unity power factor with minimum harmonic distortion and lower switching losses.

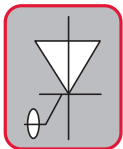

GCT-based Converter and Inverter, TM-80
Both the converter and inverter use state-of-the-art technology and design based on the Gate Commutated Turn-off thyristor (GCT).

Drive Capable of Higher Capacity

The GCT phase leg assemblies provide high power at near unity power factor with minimum harmonic distortion.

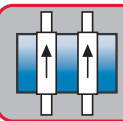

Water-Cooled Power Bridge
Draw-out phase leg assemblies are water-cooled and have quick disconnect fittings.

Equipment Footprint Reduced

Efficient water-cooling allows reduced drive footprint, saving valuable space in your facility.



Modular Design
Power bridge assemblies come in convenient draw-out modules.

Maintenance Minimized

Modular power bridge assemblies and quick disconnects minimize the time for any maintenance activities.



High-Speed Switching
The IEGT is switched at a rate of 500 Hz in the TM-70, and the power bridge is a three-level design.

Motor and Power System Friendly

The high-speed switching coupled with the bridge design delivers a smooth sine wave to the motor and power system.

Flexible Topologies to Meet Your Needs

The TMdrive-70 8000/10000 Frame IEGT regenerative Converter and Inverter are shown below. A non-regenerative diode converter is also available. Converter and inverter banks can be paralleled to obtain high powers for driving large induction or synchronous motors.

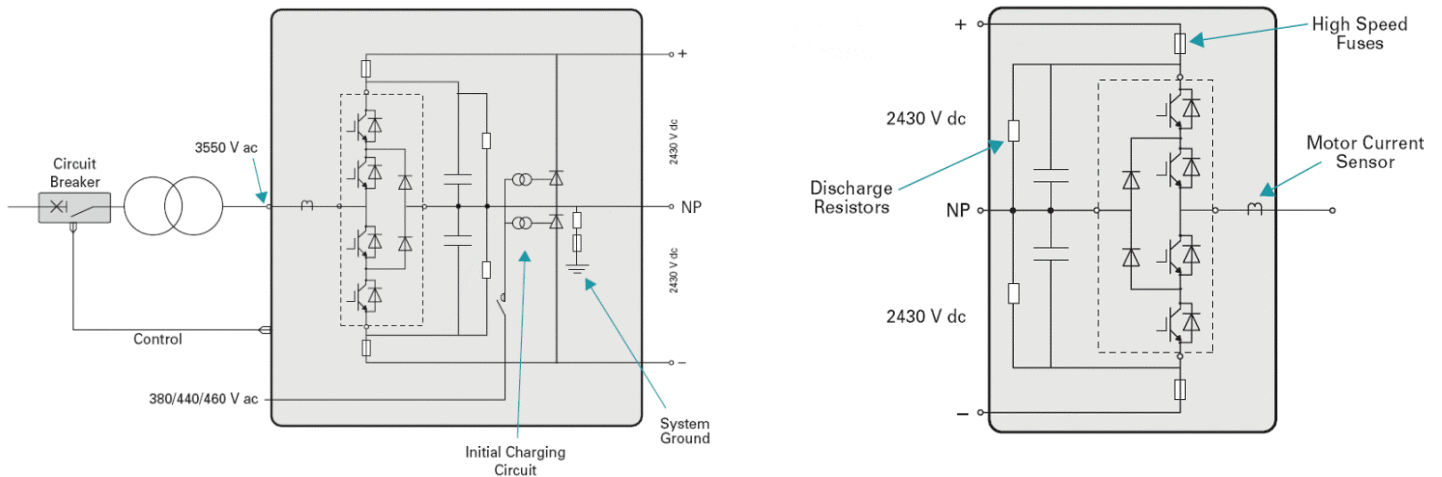

Three-Level Phase Leg Assembly for both Converter and Inverter – TM-70

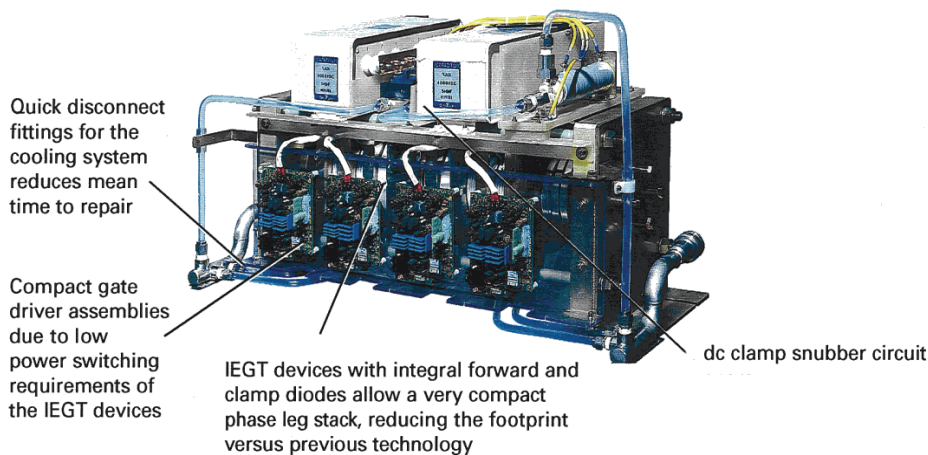

TM-70 Phase Leg Assembly



TM-70 10MVA Converter 10 MVA Inverter
 TM-80 14 MVA Converter 14 MVA Inverter

Additional Features - TM-70

- Control cards common to the TMEIC drive family.
- Common Microsoft Windows-based configuration software with local or remote connectivity.
- High drive efficiency of 98.5% at rated load.
- Oil-filled DC capacitors to provide long life.
- Field exciter available for synchronous motors.
- Operation at 0° to +40°C; up to +50°C with derating.
- Vector control speed regulation $\pm 0.01\%$ with speed sensor; $\pm 0.1\%$ without.
- Vector control torque linearity $\pm 3\%$ with temp sensor, for induction motor.
- Very low motor current harmonic distortion.

TMdrive-XL85, the 7.2 kV Drive for High Power Applications

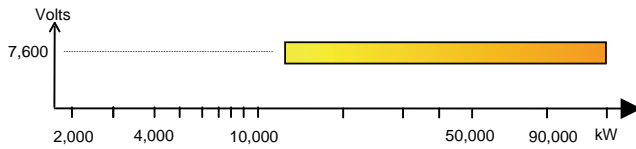

The TMdrive-XL85 is a medium voltage, ac fed drive designed for high-efficiency and power-friendly operation in a broad range of industrial applications.

High reliability, low harmonic distortion, and high power factor operation are designed into the drive.

The TMdrive-XL85 is available with up to 7.2 kV class voltage output.

Features

Benefits

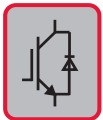

Conservative design using 6000 V - 6000 A GCTs

Highly reliable operation, expected 20 year drive MTBF



High energy efficiency approximately 98.6%

Considerable energy savings

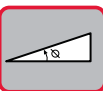

Diode rectifier ensures power factor greater than 95% in the speed control range

Capacitors not required for power factor correction

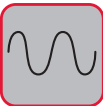

36-pulse converter rectifier by using separated phase shifted transformer

No harmonic filter required to provide lower harmonic distortion levels than IEEE-519-1992 guidelines

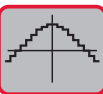

Multiple level drive output waveform to the motor (five levels for the 7.2 kV inverter)

Suitable for standard motors due to motor-friendly waveform

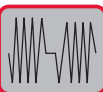

Synchronous transfer to line option with no interruption to motor current

Allows control of multiple motors with one drive
No motor current or torque transients when the motor transitions to the AC line

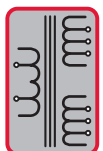

Separated input isolation transformer included in drive package

Less power loss in Drive Room
Less total space required
Simplifies design and installation

TMdrive-XL85 Adjustable Speed Drive

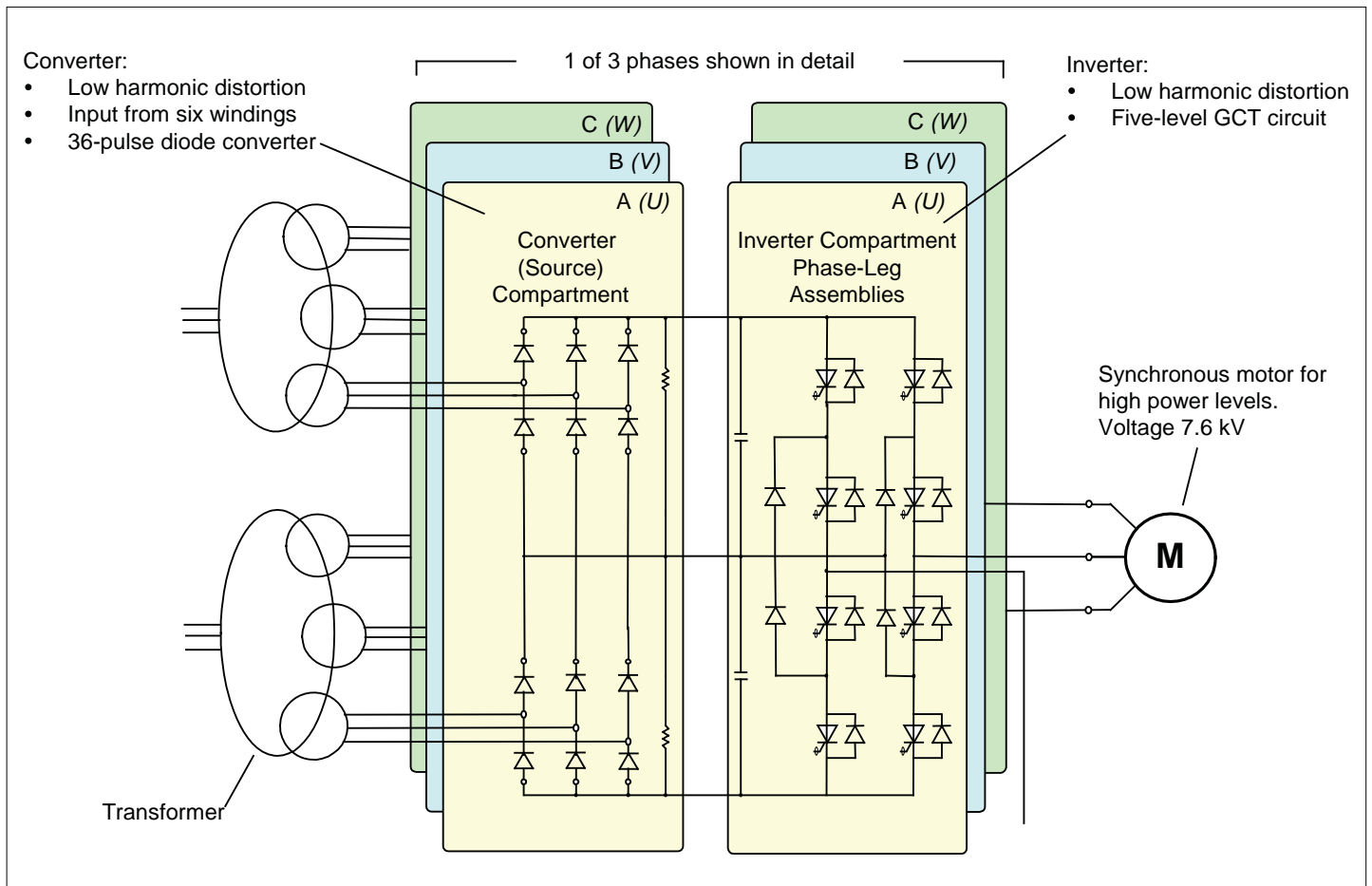

Redundant TMdrive-XL85 Configuration

A redundant configuration of the TMdrive-XL85 can be built using four active channels (blocks) connected as shown in the diagram. The system has:

- Four transformers and four TMdrive-XL85 channels.
- Four parallel connections.
- A very clean waveform.
- Contacts to isolate any one channel.

The redundant function is as follows:

1. A problem is detected in one channel.
2. The suspect channel is isolated and stopped.
3. The three other channels continue operation and deliver full power to the motor.
4. The out-of-service channel is repaired and brought back on line.

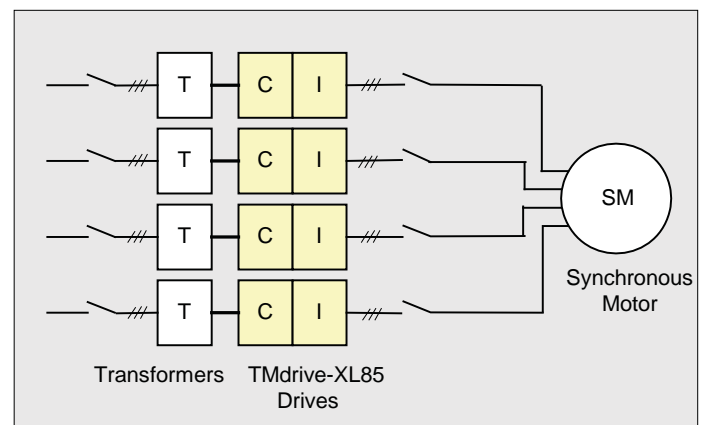

Simplified Block Diagram of Redundant VSD

Appendix - Energy Savings Payback Calculations

Replacing a mechanical speed control device with an adjustable speed drive usually produces large energy savings plus a reduction in maintenance costs. This appendix outlines how the energy savings can be calculated as follows:

1. Calculate the cost of energy used by the electric drive speed control system, outlined on this page.
2. Calculate the cost of energy used by the mechanical speed control system, outlined on the next page.

The difference is the **energy cost savings**. Typical power consumption curves for pumps and fans are shown below.

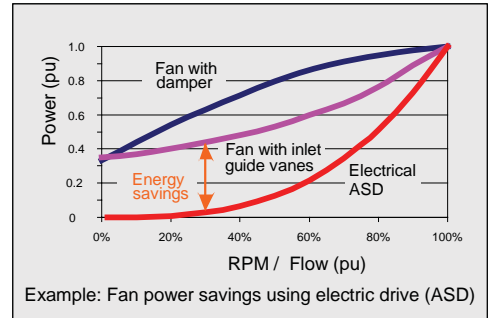
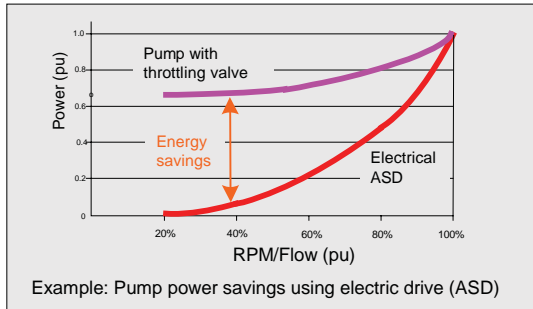

An example of the energy cost calculation for a pump driven by a motor and electric drive is shown below. The calculation for the mechanical system is similar and is described on the next page. Since energy consumption varies with speed and flow, you need the load profile table which shows the number of hours running at the various flows.

Energy Cost for Electric Drive Speed Control

Step	Description	Value
Step 1	Desired Flow	90%
Step 2	Input Shaft hp	1,500
Step 3	Motor Shaft kW	1,119
Step 4	Motor Input kW	1,169
Step 5	Motor Efficiency	95.7%
Step 6	Drive Efficiency	96.5%
Step 7	Input kW	1,212
Step 8	Energy Cost	\$371,500/yr
Step 9	Energy Cost	\$0.07/kWh

Step	Calculation details	Example
Step 1	Select the desired pump output flow, for example 90%, and number of hours/day at this flow, for example 12.	
Step 2	Obtain the variable speed pump performance chart and the load pressure-flow curve, which is the flow resistance of the process being fed.	
Step 3	Find the pump input power.	
Step 4	Convert the input shaft horsepower to shaft kW	Conversion: Horsepower x 0.746 = kW
Step 5	Obtain the electric motor efficiency	Example: Induction motor efficiency 95.7% from manufacturer's data sheets (find at each RPM)
Step 6	Obtain the adjustable speed drive efficiency	Example: Drive efficiency 96.5% from manufacturer's data sheets (find at each RPM)
Step 7	Obtain the electric power cost	Example: Energy cost = \$0.07/kWh. Calculate cost for the hours at this flow from load profile; in this example it is 12 hours/day.

Step 1

Select the desired pump output flow, for example 90%, and number of hours/day at this flow, for example 12.

Step 2

Obtain the variable speed pump performance chart and the load pressure-flow curve, which is the flow resistance of the process being fed.

Step 3

Find the pump input power.

Overlay the load pressure-flow curve on the pump chart and find the pump input shaft horsepower at the 90% flow (point B). You need the load profile. See example below.

Pump input power at N2 rpm = 1,500 hp at point B, 90% flow.

Daily Load Profile (example)

Operation Hours/day	5	12	5	1	1
Percent Flow	100%	90%	80%	70%	60%

Step 4	Convert the input shaft horsepower to shaft kW	Input shaft kW = 1,500 hp x 0.746 = 1,119 kW
Step 5	Obtain the electric motor efficiency	Motor input power = 1,119 kW / 0.957 Efficiency = 1,169 kW
Step 6	Obtain the adjustable speed drive efficiency	Drive input power = 1,169 kW / 0.965 Efficiency = 1,212 kW
Step 7	Obtain the electric power cost	Energy cost = 1,212 kW x 0.07 \$/kWh x 12 hrs/day x 365 days per year = \$371,500 per year. (Repeat calculation for other flows in load profile and total).

Calculations for Mechanical Speed Control Systems

If the energy cost is to be compared with a mechanical variable speed system, the previous calculation must be repeated. There are three main mechanical flow control systems as described in the large table of pages 4 and 5:

- A fixed speed motor and pump, compressor, or fan with a flow throttling valve or variable guide vanes.
- A fixed speed motor and hydraulic variable speed transmission driving a variable speed pump or compressor.
- A variable speed steam or gas turbine driving a variable speed pump or compressor.

The methods for calculating these costs are outlined in the chart below. A load profile similar to the previous page is used. Spreadsheets for calculating the savings and payback for a fan are available from the website www.tmeic.com.

Flow Throttling Valve Control

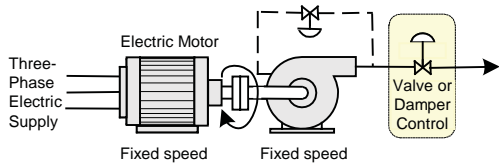
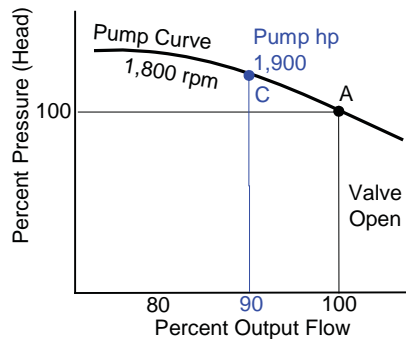

Fig. 1 Pump Performance Chart & Load Curve



To calculate the energy used by a flow throttling system, start with the desired output flow, say 90%. Obtain the pump performance chart (head vs flow, with pump horsepower). Find the horsepower required when the pump is running at the fixed motor speed of 1,800 rpm and delivering the reduced flow at C in Figure 1. Proceed as in the electrical example, working back to the motor. Calculate the shaft kW used and the electrical power cost. References below give examples.

Repeat for the other flows in the load profile, and total the energy usage.

Hydraulic Variable Speed Control

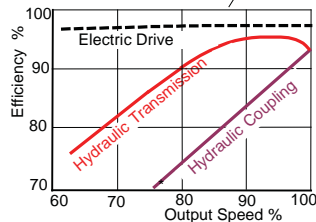
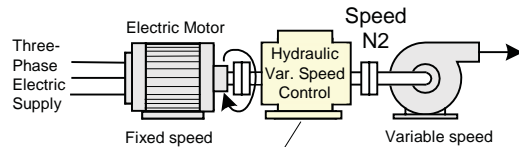
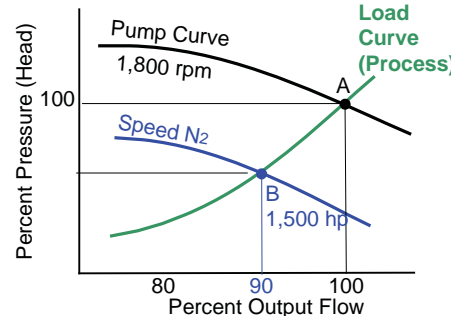

Figure 2. Hydraulic Transmission Efficiency

Fig. 3 Pump Performance Chart & Load Curve



To calculate the energy used by a variable speed hydraulic transmission system, start with the desired pump output flow. Using the pump chart, find the horsepower required when the pump is running at the reduced speed N2 and delivering the reduced flow at B in Figure 3. Obtain the transmission efficiency from the manufacturer (Figure 2). Note the low efficiency at reduced speeds. Proceed as in the electrical example, working back to the motor and calculating the energy cost. Reference 1 gives examples.

Repeat for the other flows in the profile and total the energy usage.

Variable Speed Turbine Control

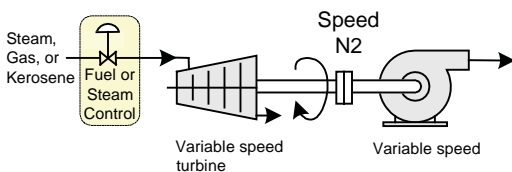
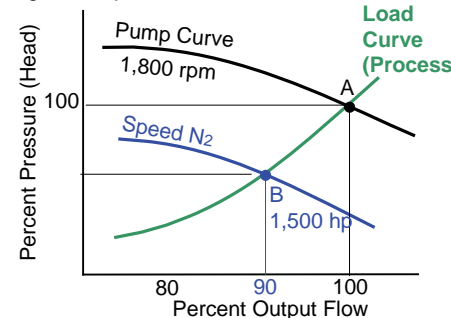

Fig. 4 Pump Performance Chart & Load Curve



To calculate the energy used by a variable speed turbine system, take the pump chart and load curve. Find the horsepower required when the pump is running at the reduced speed N2 and delivering the reduced flow at B in Figure 4. Find the turbine fuel or steam consumption at this speed and calculate the cost for the number of running hours.

Repeat for the other flows in the profile and total the energy usage.

A number of free publications on this topic are available from the library at www.tmeic.com, including the following:

1. *Selecting Variable Speed Drives for Flow Control* - discusses the various mechanical speed control systems and outlines the calculation of energy savings, in particular for hydraulic transmission speed control.
2. *Adjustable Frequency Drives for Pump Energy Savings in Power Generating Stations* - discusses pump energy calculations.
3. *AC Adjustable Speed Drive Systems for Cement Kiln Induced Draft Fans* - discusses large fan energy calculations.

Medium Voltage Motor and Drives Systems School

TMEIC is pleased to offer its tuition-free MV Motor and Drives Systems School to its customers. These schools are offered regularly in Roanoke, Virginia, and other cities.



Course Topics:

- Medium Voltage (MV) induction and synchronous motors
- Fundamentals of variable frequency drives
- MV drive characteristics, payback, and specifications
- MV power systems design concepts
- MV switchgear, starters, transformers, reactors, and substations
- MV system protection
- Real-world industrial application stories from the cement, oil & gas, petrochemical, mining, and water & waste water industries
- Equipment demonstrations

For details and registration for our next school, please visit our website at www.tmeic.com

Global Office Locations:

TMEIC Corporation
Roanoke, Virginia, USA
Tel: +1-540-283-2000
Email: OilGas@tmeic.com
Web: www.tmeic.com

TMEIC Corporation
Houston Branch Office
Tel: +1-832-767-2680
Email: OilGas@tmeic.com
Web: www.tmeic.com

TOSHIBA MITSUBISHI-ELECTRIC INDUSTRIAL SYSTEMS CORPORATION (TMEIC)
Tokyo, Japan
Tel: +81-3-5444-3828
Web: www.tmeic.co.jp

TMEIC Europe Limited
Uxbridge, Middlesex, United Kingdom
Email: info@tmeic.eu
Web: www.tmeic.eu

TMEIC Industrial Systems India Private Limited
Andhra Pradesh, India
Email: inquiry_india@tmeic.com
Web: www.tmeic.in

TOSHIBA MITSUBISHI-ELECTRIC INDUSTRIAL SYSTEMS (Beijing) CORPORATION
Email: sales@tmeic-cn.com
Web: www.tmeic-cn.com

TOSHIBA MITSUBISHI-ELECTRIC INDUSTRIAL SYSTEMS (Shanghai) CORPORATION
Email: sales@tmeic-cn.com
Web: www.tmeic-cn.com

TMEIC Asia Company Ltd.
Kowloon Bay, Hong Kong
Web: www.tmeic.com

TMEIC Asia Company, Ltd. Rep. Office
Kaohsiung, Taiwan
Web: www.tmeic.com

All specifications in this document are subject to change without notice. This brochure is provided free of charge and without obligation to the reader or to TMEIC Corporation. TMEIC Corporation does not accept, nor imply, the acceptance of any liability with regard to the use of the information provided. TMEIC Corporation provides the information included herein as is and without warranty of any kind, express or implied, including, but not limited to, any implied statutory warranty of merchantability or fitness for particular purposes. The information is provided solely as a general reference to the potential benefits that may be attributable to the technology discussed. Individual results may vary. Independent analysis and testing of each application is required to determine the results and benefits to be achieved from the technology discussed.

TMDrive is a registered trademark of TOSHIBA MITSUBISHI-ELECTRIC INDUSTRIAL SYSTEMS CORPORATION.
TMEIC is a registered trademark of TOSHIBA MITSUBISHI-ELECTRIC INDUSTRIAL SYSTEMS CORPORATION.
TM is a registered trademark of TOSHIBA MITSUBISHI-ELECTRIC INDUSTRIAL SYSTEMS CORPORATION.