



## TMdrive<sup>®</sup>-70 Product Application Guide

Medium Voltage 3-Level IEGT System Drive

metals

cranes

mining

testing

oil & gas

renewable  
energy

power  
generation

cement

The family of TMDrive® ac system drives is targeting specific customer requirements for:

- High reliability
- Simple configuration and maintenance
- Low cost of ownership

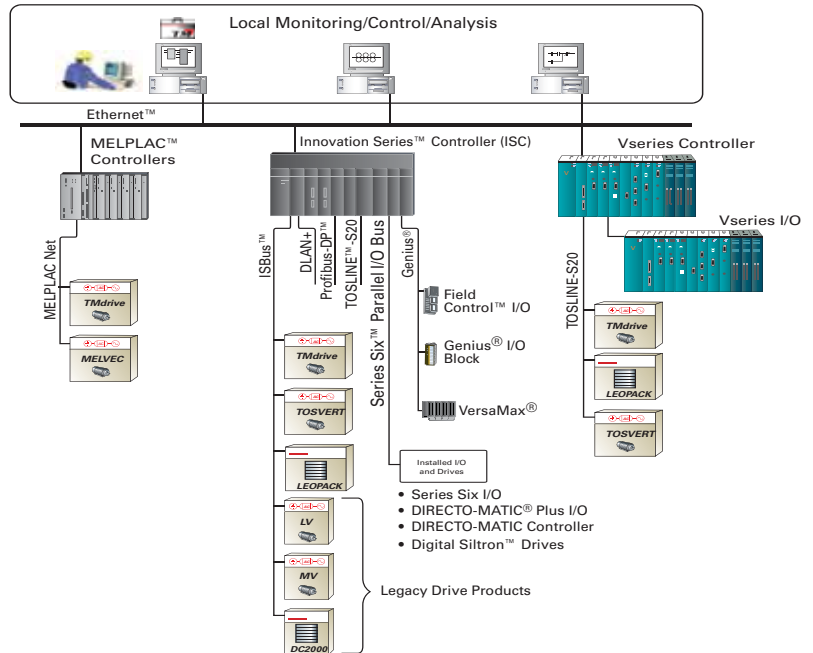

## IEGT Technology Dramatically Lowers Cost of Ownership

The Injection Enhanced Gate Transistor (IEGT) is a breakthrough in power switch technology. The following set of features and associated benefits details how this device lowers your cost of ownership versus previous main drive technology.



### Features

- **Low Voltage Gate Drive**  
Given that the IEGT is a MOS structure, it can be gated (turned on/off) with  $\pm 15$  V.
- **Minimal Snubber Circuitry**  
With the high  $dV/dt$  capability of the IEGT, there is only need for a small dc clamp snubber circuit.
- **High-Speed Switching**  
The IEGT is switched at a rate of 500 Hz in this application.

### Benefits

- **High Efficiency and Small Size**  
A very compact phase leg assembly is achieved with:
  - A reduction in snubber circuitry
  - Integral forward diodes
  - Integral clamp diodes
- **Higher Performance**  
The reduction in snubber circuitry allows a higher chopping frequency, lowering the torque ripple applied to the motor and harmonics fed back into the power system.
- **Motor and Power System Friendly**  
The high-speed switching coupled with the three-level power bridge design delivers a smooth sine wave to the motor and power system.

# Bringing Reliable Control To System Applications

High-power, precision-controlled processes are ideally suited for the TMdrive-70 with its efficient high current IEGT power devices and control cards common to the drive family. Flexible arrangement of converter, inverter and cooling units allows for maximum power density, resulting in minimum floor space, and installation cost.



Coordinated drive systems are an integral part of numerous manufacturing processes in the metals industry. TMdrive system drives address all of these applications with a robust control platform and a common Microsoft Windows-based tool. The tool supports local and remote connectivity, and is an invaluable asset for system and process analysis.

Due to its high reliability, simplicity of design and high efficiency, the TMdrive-70 is perfect for compressor, fan and pumping applications. It provides accurate speed control and high efficiency while eliminating the need for high maintenance mechanical flow control devices. The TMdrive-70 is also well suited for applications like grinding mills and mine hoists, where high overloads and impacts are a part of everyday operations.



# A Look Inside

## State-of-the-Art Technology:

- Injection Enhanced Gate Transistor (IEGT)-based converter and inverter provides power to the process at near unity power factor with minimum harmonic distortion
- Water-cooling technology for the power bridge reduces the footprint of the equipment saving valuable space in your factory
- Modular design for power bridge minimizes the time required for any maintenance activities

Control Cabinet

Converter Front View

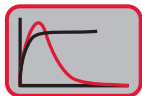

### Control Functions

Each inverter and regenerative converter shares a

common set of control boards. The primary control board performs several functions:

- Speed and torque regulation
  - Sequencing
  - I/O mapping
  - Diagnostic data gathering
- A mounting bracket is provided for an optional LAN interface board.



### I/O Board

The I/O board supports encoder or resolver, 24 V dc I/O, 115 V ac inputs and analog I/O, standard. All I/O are terminated to a two-piece modular terminal block for ease of maintenance.

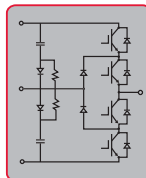

### IEGT Three-Level Phase Leg Assembly

The drive has a total of six identical Injection Enhanced Gate Transistor (IEGT) phase leg assemblies in the converter and inverter. The modular draw-out assembly includes:

- Four IEGT power semiconductors with integrated flyback diodes
- Neutral-point clamp diodes
- Water-cooled piping assembly with quick disconnect fittings
- IEGT gate driver circuit board
- Feedback control circuitry
- dc clamp snubber mounted on top

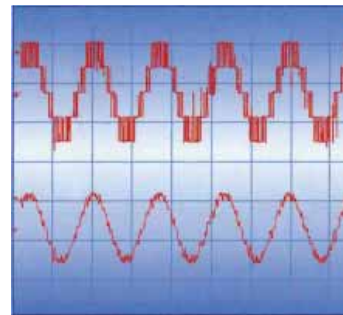

### Inverter Front View



### Optional Remote Control

Modular construction allows the power converter and control cabinets to be installed up to 150 m (500 ft) apart.

This optimizes the use of space in your equipment room.



### dc Bus

The converter generates dc power for the inverter. The inverter then creates variable frequency ac power to control the induction or synchronous motor. The dc power between the converter and inverter is conveyed on a solid copper bus behind the phase leg assemblies in both cabinets. For common bus systems this bus is extended to adjacent cases.

### Inverter Back View

### Converter Back View

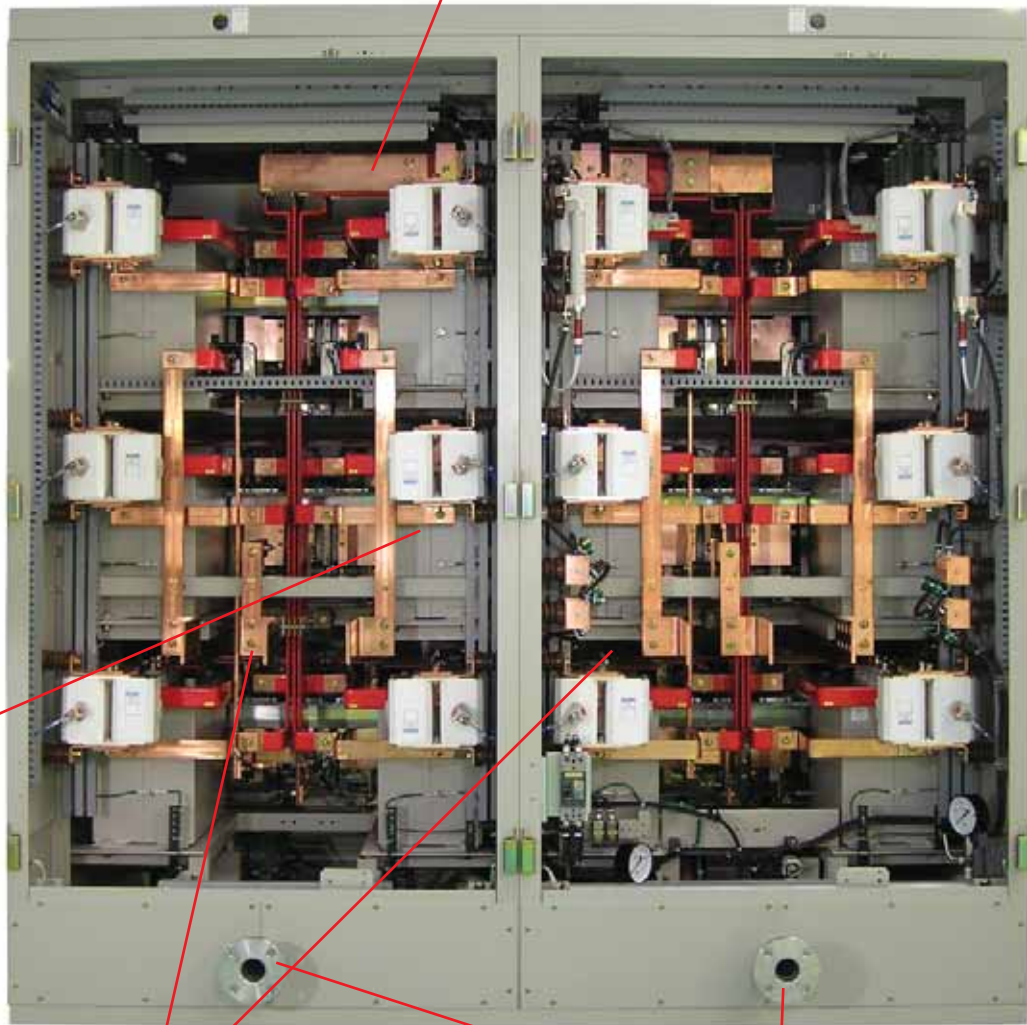

Output Voltage

Output Current



### Main Capacitors

Oil filled dc capacitors are used to provide long life under all service conditions and duty cycles.



### Main Power

3-Phase motor and transformer are made in the rear. Both top and bottom e supported.



### Cooling Water Interface

150 mm JIS-10K50A fittings are provided for connecting cooling water for de-ionized cooling loop. Water interface shown here is for "separate" type water conditioner.

# Flexible Topologies To Match Your Needs

## TMdrive-70 IEGT Inverter

8000 Frame  
10000 Frame

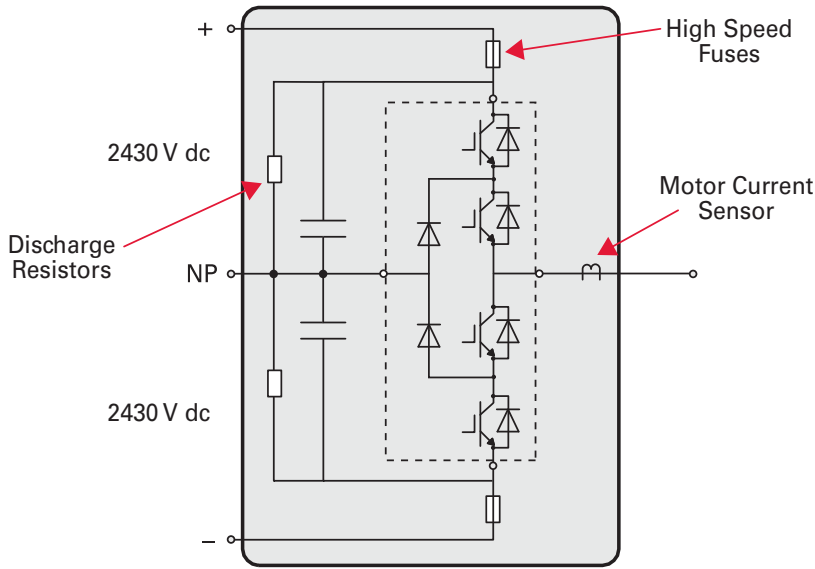

## TMdrive-P70™ Regenerative IEGT Converter

8000 Frame  
10000 Frame

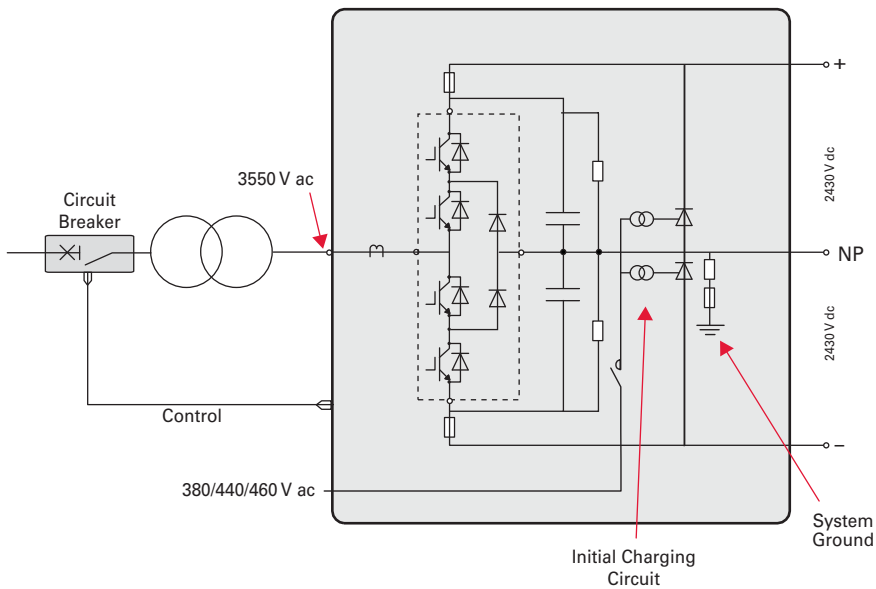

## Configuration Options

1 Bank Converter  
1 Bank Inverter



4 Bank Converter  
4 Bank Inverter

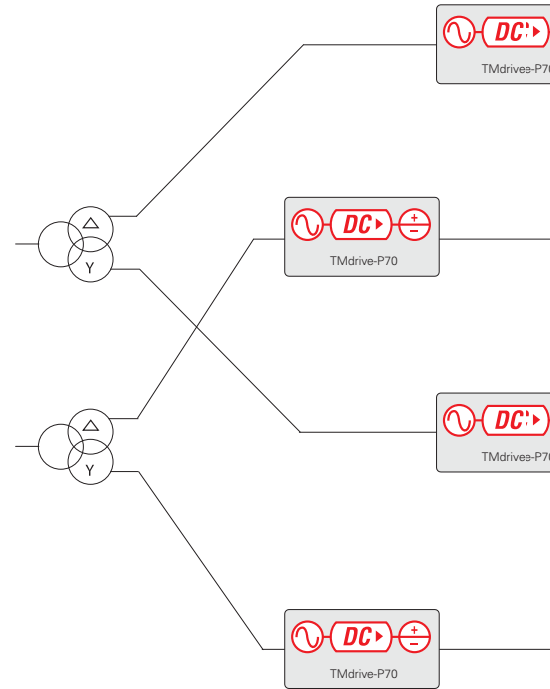

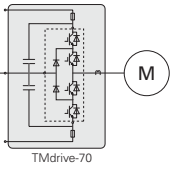

1 Bank Converter  
2x1 Bank Inverter

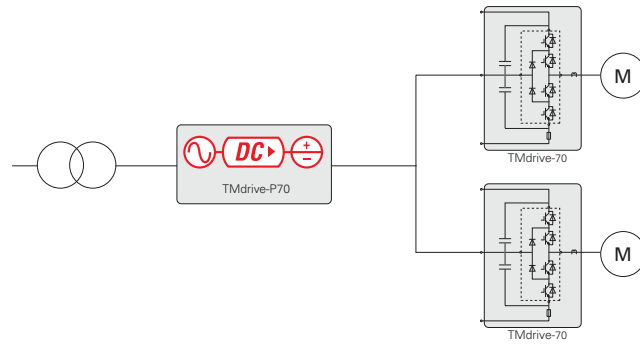

2 Bank Converter  
2 Bank Inverter

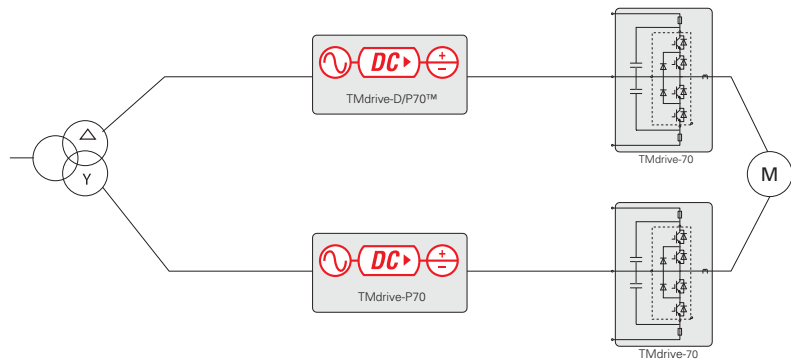

2 Bank Converter  
3x1 Bank Inverter

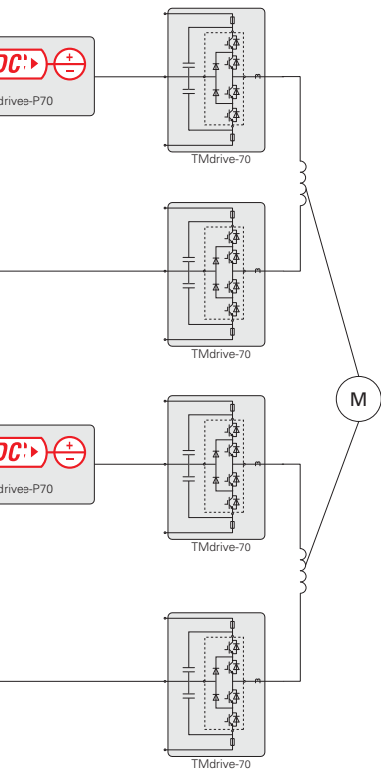
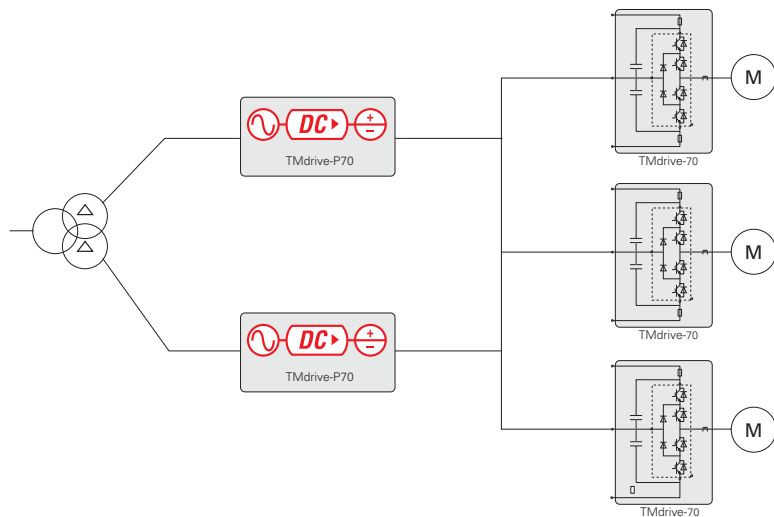

# Regenerative Systems



## Three-Level Phase Leg Assembly for Both Converter and Inverter

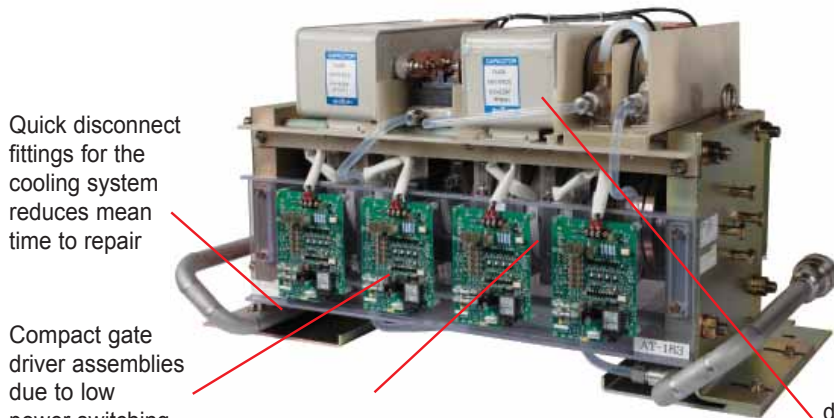

Quick disconnect fittings for the cooling system reduces mean time to repair

Compact gate driver assemblies due to low power switching requirements of the IEGT devices

IEGT devices with integral forward and clamp diodes allow a very compact phase leg stack, reducing the footprint versus previous technology

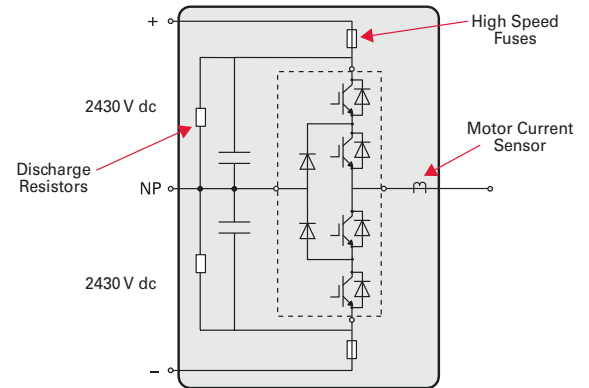

dc clamp snubber circuit used to absorb the energy generated in turning off the IEGTs

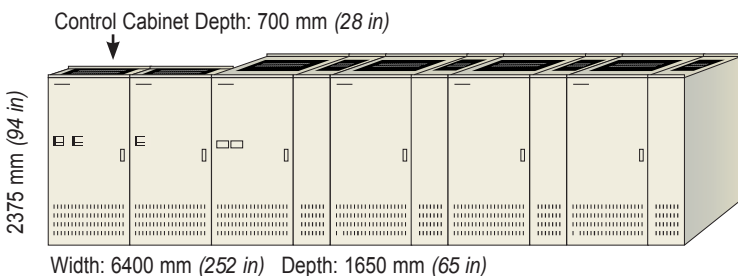
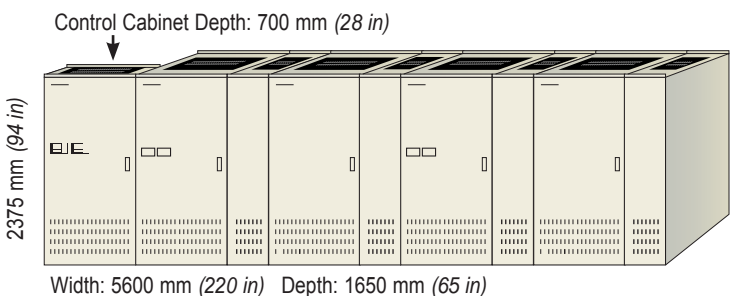
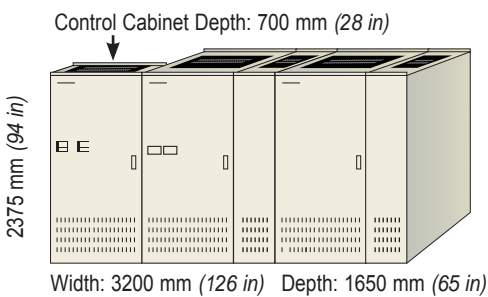

Banks	Frame	Weight kg (lbs)	Control Power kVA	Motor Current A ac	Allowable Overload %
1	8000	4900 (10780)	3.8	1360	150
				1166	175
				1020	200
				907	225
				816	250
	10000	5200 (11440)	3.8	1700	150
				1457	175
				1275	200
				1133	225
				1020	250
2	16000	9500 (20900)	7.2	2720	150
				2331	175
				2040	200
				1813	225
				1632	250
	20000	10200 (22400)	7.2	3400	150
				2914	175
				2550	200
				2267	225
				2040	250
4	32000	19000 (41800)	14.3	5440	150
				4663	175
				4080	200
				3627	225
				3264	250
	40000	20300 (44660)	14.3	6800	150
				5829	175
				5100	200
				4533	225
				4080	250





## Environmental (Inverters and Converters)

Operating Air Temperature	0 to 40°C (32 to 104°F) at rated load 0 to 50°C (32 to 122°F) with derating
Storage Temperature	-20 to 55°C (-13 to 131°F)
Humidity	5 to 95% relative humidity Non-condensing
Altitude	0 to 1000 m above sea level
Vibration	10-50 Hz, <0.5 G
Operating Water Temperature	10°C - 32°C at inlet 10°C - 35°C at inlet with derate Outlet temperature is inlet + 6°C



## Motor Control

With Speed Sensor (Resolver or Encoder)

- Speed regulator accuracy: +/- 0.01%
- Maximum speed response: 60 rad/sec
- Torque linearity: +/- 10% Synchronous motors
- Torque linearity: +/- 3% with temperature sensor  
+/- 10% without temperature sensor
- Maximum Torque current response: 600 rad/sec
- Torque range: 0-400% of rated motor torque
- Maximum flux control range: 20%-100%

} Induction  
Motor

Without Speed Sensor (Induction Motor Only)

- Speed regulator accuracy: +/- 0.1% with temperature sensor  
+/- 0.2% without temperature sensor
- (Using 1% slip motor at rated flux)
- Maximum speed regulator response: 20 rad/sec
- Minimum continuous speed: 3%
- Torque linearity: +/- 10%
- Maximum Torque current response: 600 rad/sec
- Torque range: 0-150% of rated motor torque
- Maximum flux control range: 75%-100%

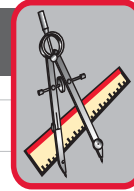

## Mechanical (Inverters and Converters)

Enclosure	IP 20 (NEMA 1)
Cable Entrance	Top or bottom
Wire Colors	Per CSA/UL and CI
Short Circuit Ratings	100 kA for ac and dc buswork 25 kA for control power
Acoustic Noise	66-68 dB @ 150% OL, 1 m from cabinet in all directions, 1.5 m in height above the floor



## Power Input/Output

Input Voltage	3550 V for Fixed Pulse Pattern type 3100 V for Carrier Comparison type
Input Voltage Variation	+/- 10%, Continuous operation below nominal requires derate
Input Frequency	50/60 Hz
Input Chopping	Approx. 500 Hz
Input Harmonics	TMdrive-P70 – IEEE 519 Compliant
Control Power	Control and Blowers 180-220 Vac, 50Hz 3-Phase 198-242 Vac, 60 Hz 3-Phase Pumps and Precharge 380-440 Vac, 50/60 Hz 3-Phase
Displacement Power Factor	0.98 TMdrive-P70 see page 11
Output Frequency	0-60 Hz, 0-90 Hz with derate
Output Chopping Frequency	512 Hz
Efficiency	98.5% at rated load

# Water Conditioning Equipment

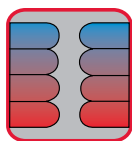

Water conditioning control panel continuously monitors the status of the water system. Separate fault indications help find and fix problems fast.

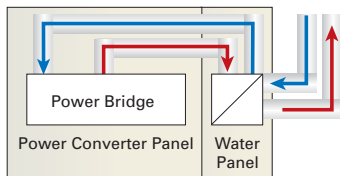

Integrated water system has internal plumbing for de-ionized cooling loop.

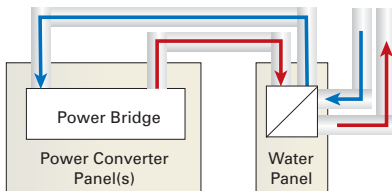

Separate type cooling has field-installed plumbing for de-ionized cooling loop.



Water to water heat exchanger keeps the de-ionized system isolated from the plant water supply.

Surge tank absorbs water during pump transients and indicates the internal cooling loop water level.

De-ionizer removes contaminants for the internal cooling loop.

Redundant pumps keep the system running even if one pump fails

Type	Capacity	Width mm (in)	Depth mm (in)	Height mm (in)	Weight kg (lbs)	kVA	Notes
Integrated with Lineup	125 kW	1200 (48)	1650 (65)	2375 (94)	1600 (3527)	5	Capacity for one converter/inverter, (1 bank) Plant water required: 300 l/min (80 gal/min)
Separate Cabinet	250 kW	1200 (48)	2000 (79)	2500 (99)	1650 (3638)	10	Capacity for two converters/inverters, (2 bank) Plant water required: 600 l/min (160 gal/min)
Separate Cabinet	500 kW	3000 (118)	2000 (79)	2500 (99)	2650 (5842)	15	Plant water required: 1200 l/min (4 bank) (320 gal/min)
Separate Cabinet	750 kW	4300 (170)	2000 (79)	2500 (99)	4300 (9480)	25	Plant water required: 1800 l/min (6 bank) (475 gal/min)

## Advanced PWM Technology

Advanced PWM control brings enhanced efficiency and reduced harmonics to TDrive-70 systems. Fixed pulse pattern gate control uses optimum gating sequences to almost eliminate switching losses in the IEGT device. Gating sequences are pre-computed for the control rather than computed at runtime. The result is performance that reduces losses and harmonics.

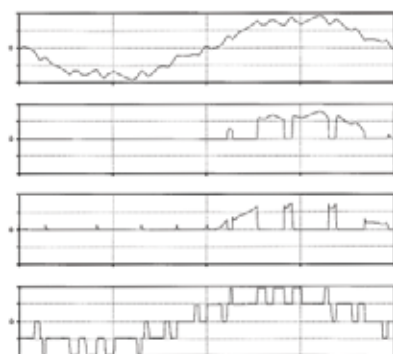

Conventional PWM

Input Current

Diode Current

IEGT Current

Output Voltage

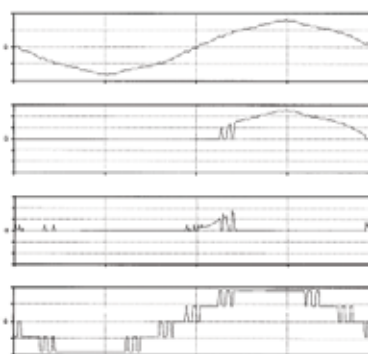

Fixed Pulse Pattern Control

# Field Supply Specifications

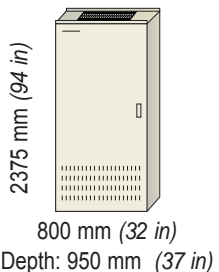
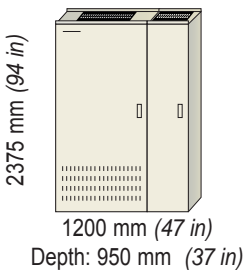
	Frame	Weight kg (lbs)	Control Power KVA	Voltage Vac (Vdc)
 <p>2375 mm (94 in) 800 mm (32 in) Depth: 950 mm (37 in)</p>	1200	300 (660)	0.5	500 (675)
 <p>2375 mm (94 in) 1200 mm (47 in) Depth: 950 mm (37 in)</p>	2100	700 (1540)	0.5	500 (675)

AC Leg Fuses protect power bridge from faults on the ac line

Autonomous Crowbar prevents dangerous motor voltages from developing under certain fault conditions

## 2100 Frame Field Supply

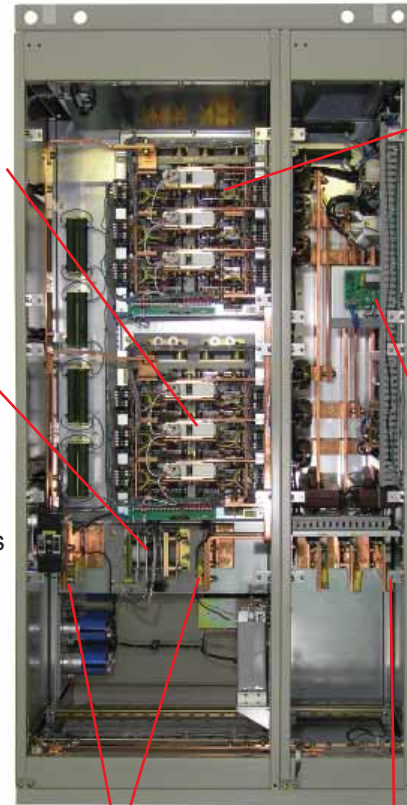

Main Power module. One module is applied for the 1200A supply and two modules for the 2100A model.

Ground Fault detection module provides indication of insulation failure

DC Field Connection Bus

AC Connection Bus. AC voltages up to 500 Vac can be connected depending on required voltage

Type	Overload Time (sec)	Field Exciter Continuous Current Rating, dc Amps											
		50 Hz						60 Hz					
		150%	175%	200%	225%	250%	300%	150%	175%	200%	225%	250%	300%
1200 A	10	1320	1200	1100	1010	940	810	1360	1240	1130	1040	960	830
	30	1230	1100	1000	900	820	710	1280	1130	1020	915	845	720
	60	1180	1040	920	830	760	645	1205	1060	945	850	775	660
	120	1120	980	860	760	690	585	1160	1000	885	790	710	590
2100 A	10	2376	2160	1980	1818	1692	1458	2448	2232	2034	1872	1728	1494
	30	2214	1980	1800	1620	1476	1278	2304	2034	1836	1647	1521	1296
	60	2124	1872	1656	1494	1368	1161	2169	1908	1701	1530	1395	1188
	120	2016	1764	1548	1368	1242	1053	2088	1800	1593	1422	1278	1062

## Enhanced Converter Technology

### TMdrive-P70 VAR Control

The TMdrive-P70 converter can be configured in two modes, providing VAR Control within the limits of its current capacity.

One mode is the conventional PWM type normally set to hold unity power factor for all load conditions. (Shown in red)

Another mode is the Fixed Pattern type, providing voltage stability, improved harmonics and efficiency. The Fixed Pattern mode stabilizes line voltage by providing system VARs when line voltage is low and drawing VARs from the system when the voltage is high. By convention, VARs from the system are (+) and cause the line voltage to drop while VARs from the converter are (-) and cause the line voltage to rise. The relationship of line voltage, loads MW and converter MVAR is shown by the blue voltage lines depending on the measured line voltage.

### MVA vs. MW and Voltage

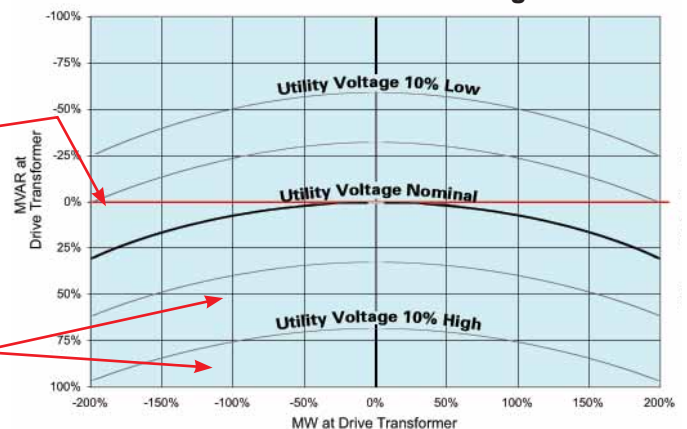

# Application Examples

## Applying the TMdrive-70 Starts With the Motor Design

Consideration must be given to motor design when applying the TMdrive-70. A primary constraint is the motor terminal voltage. It is important that the motor terminal voltage does not exceed 3400Vac under any operating condition. Reserving voltage margin correctly is critical to success. Detailed motor design data is needed for correct application.

**OL\_V** Overload derate. The rated motor voltage over the terminal voltage of the motor at maximum applied overload. Motors with no overload use 1.0.

**ST\_V** Field forcing margin needed when applying synchronous motors. Apply 0.94 for synchronous motor systems.

**RP\_V** Reduction in maximum voltage due to the dc bus ripple of the drive at low frequencies. If the base frequency is below 5 Hz then this derate is 0.97, otherwise it is 1.0.

**SP\_V** Speed margin. For motors that run above base speed this is the ratio of the terminal voltage at base speed over the terminal voltage at top speed under maximum overload at each point. Other motors use 1.0.

$$\text{Maximum Rated Motor Voltage} = 3400 \times OL\_V \times RP\_V \times ST\_V \times SP\_V$$

Experience has shown that the following maximum rated motor voltages apply based on the type of motor and the application.

Induction (Maximum Voltage at max OL and top speed)	Synchronous Maximum Rated Motor Volts	Rated Motor Frequency	Overload Requirement	Example Application
3400	3300	60 Hz	100%	Pump or Fan
3300	3200	30 Hz	200%	Mine Hoist
3200	3100	5 Hz	225%	Mill Stand

## TMdrive-70 Notes

- Power bridge cabinets are 1650 mm (65in) in depth. Control cabinets are 700 mm (28 in) in depth. Dimensions do not include required 50 mm (2 in) channel base.
- Allocate a minimum of 550 mm (20 in) above cabinet for fan maintenance.
- Power rating data assumes ambient temperature of 0-40 °C (32-104 °F), altitude up to 1000 m (3280 ft) above sea level.
- The specified current ratings are continuous to which the indicated overload may be applied for a maximum of 60 seconds.
- Each cabinet requires 3-phase control power.
- For high performance torque regulation, a temperature sensor is mounted in the motor.
- All TMdrive-70 cabinets require 1000 mm (40 in) back access for connections and maintenance.
- Speed and current regulator responses are computed per the adjacent figure in radians/s. Speed regulator responses shown are maximum available. Actual response will be limited by drive train mechanical conditions. Accuracy and linearity specifications shown are as measured under controlled conditions in our lab and while typical may not be achievable in all systems.
- Water connections for separate type cooling systems are located near the floor in the rear of power converter cabinets. The flange is 1500 mm JIS-10K50A. Stainless piping is required for plumbing of the de-ionized loop.
- dc Bus bar included in lineups is rated for one inverter only. For common bus systems, converters and inverters are arranged so that this limitation is not exceeded.
- When output or input reactors are used to parallel systems then the dc Buses of those systems must be connected together.
- Systems that share a common dc Bus must have the same winding configuration for their converter transformer secondaries.
- Field supply enclosures are typically installed directly behind control enclosures within the lineup.
- TMdrive-D70 converters require a minimum of 10% total input impedance. TMdrive-P70 converters require a minimum of 15% total input impedance.
- Systems with a base frequency below 5 Hz may require additional 800 mm (32 in) capacitor panels for each dc link.

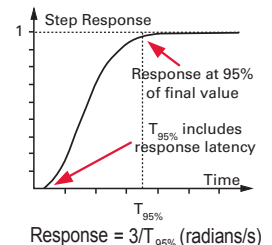

## Inverter Example

When specifying an inverter, start from the process requirements and work through the motor to the inverter. The following example illustrates this process.

**1** Define process requirements.

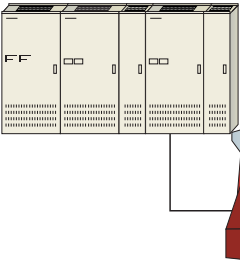

$$kW_{\text{Shaft}} = 6500 \text{ kW (8700 hp)}$$

$$500 \text{ rpm}$$

The motor delivers constant torque from zero to base speed of 500 rpm and 6500 kW (8700 hp).

Duty cycle requires 150% for 10 sec. but has rms duty cycle of 6500 kW (8700 hp).

**2** Select motor based on process requirements and compute required inverter kVA.

- 6500 kW (8700 hp)
- 500 rpm, 3100 V
- Efficiency = 0.965
- Power factor = 1.00
- Service factor = 1.0
- Synchronous

$$I_{\text{ac Inverter}} = \frac{kW_{\text{Shaft}} \times 1000 \times SF_{\text{Mtr}}}{\sqrt{3} \times V_{\text{Motor rated voltage}} \times \text{Eff}_{\text{Mtr}} \times \text{PF}_{\text{Mtr}}}$$

$$= \frac{6500 \times 1000 \times 1.0}{\sqrt{3} \times 3150 \text{ V} \times 0.965 \times 1.0}$$

$$= 1234 \text{ amps}$$

**3** Compute continuous current requirements for the inverter based on the selected motor.

**4** Select inverter based on continuous current and overload requirements.

Scan the 150% entries in the inverter tables for a frame where the continuous current rating exceeds 1234 amps. The **8000 frame** meets this criterion (**1360 amps**) and is appropriate for this application.

Current A ac	Allowable Overload %
1360	150
1166	175
1020	200
907	225
816	250

## Regenerative Converter (TMdrive-70) Example

When specifying a converter, start from the process requirements and work through the motor to the inverter, and then the associated converter. The following example illustrates this process (continuation of inverter application example from above):

**1** Compute kW requirements into the inverter. It is assumed that the converter is dedicated to the inverter specified in the application example above. It is also assumed that the converter is controlled to unity power factor.

$$kW_{\text{ac}} = \frac{kW_{\text{Shaft}}}{\text{Eff}_{\text{Mtr}}}$$

$$= \frac{6500 \text{ kW}}{0.965}$$

$$= 6736 \text{ kW}$$

**2** Compute continuous ac current requirement of the converter based on its power requirements.

$$I_{\text{ac Converter}} = \frac{kW_{\text{ac}} \times 1000}{\sqrt{3} \times V_{\text{Converter line-to-line voltage}} \times \text{Eff}_{\text{drive}}}$$

$$= \frac{6736 \text{ kW} \times 1000}{\sqrt{3} \times 3550 \text{ V} \times 0.985}$$

$$= 1112 \text{ amps}$$

Note: For sizing systems with peak powers in regenerative mode, a different equation is used to compute power requirements.

$$kW_{\text{ac}} = kW_{\text{Shaft}} \times \text{Eff}_{\text{Mtr}}$$

**3** Scan the regenerative converter table for entries that exceed your overload (150%), time (**60 sec**) and continuous current requirements (**1112 amps**). In this case the **8000 frame** TMdrive-P70 meets the requirement and is appropriate for this application.

Current A ac	Overload – Time
1360	150% – 60s
1166	175% – 60s
1020	200% – 60s
907	225% – 60s
816	250% – 60s

# A Common Control To Reduce Cost Of Ownership

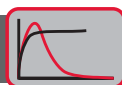

## Control Functions

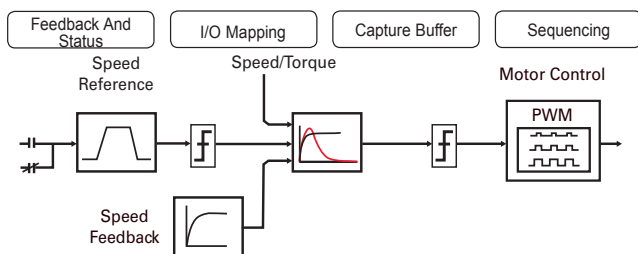

## Instrumentation Interface

### Configuration



- RJ-45 Ethernet interface
- 10 Mbps maximum
- Drive Navigator option of TOSLINE™-S20 to Ethernet connection using V-Series controller as gateway
- Toolbox option of ISBus™ to Ethernet using Innovation Series™ controller as gateway

### Meter Outputs

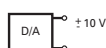

- Motor current A and B,  $\pm 10$  V
- Quantity 5 configurable,  $\pm 10$  V, 8-bit resolution



## I/O Interface

### Digital Inputs

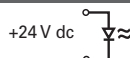

- Opto-coupled 20 mA
- Quantity 6 configurable mapping

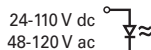

- Opto-coupled 10 mA
- Quantity 1 configurable mapping
- Quantity 1 dedicated mapping

### Digital Outputs

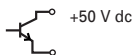

- Open collector 70 mA
- Quantity 6 user defined

### Analog Inputs



- Quantity 2  $\pm 10$  V or 4-20 mA
- Differential 8  $\Omega$  input impedance
- 12-bit resolution
- Optional Quantity 2  $\pm 10$  V - 12 bit resolution (Optional for Inverters only)

### Analog Outputs



- Quantity 4  $\pm 10$  V, 10 mA max
- User defined
- 12-bit resolution

### Speed Feedback Resolver Input

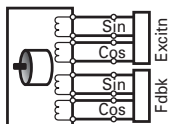

- Excitation frequency of 1 or 4 kHz
- Source for resolvers is Tamagawa: [www.tamagawa-seiki.com.jp](http://www.tamagawa-seiki.com.jp)

### (Induction Motor Only) Speed Feedback Encoder Input

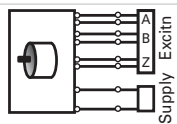

- A quad B with marker
- Maximum frequency of 100 kHz
- Differential 5 or 15 V dc
- 5 or 15 V dc at 200 mA supply

### Speed Tach Follower Output

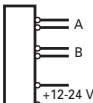

- Maximum frequency of 10 kHz
- External 15-24 V dc at 100 mA max

### Motor Temperature Feedback

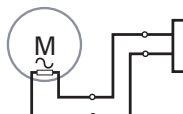

- High-resolution torque motor temperature feedback
- 100  $\Omega$  positive temperature coefficient RTD or other sensor using optional signal conditioning module

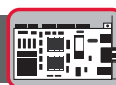

## LAN Interface Options



### TOSLINE-S20

- Supports run-time control (6 words in and 10 words out) from an Innovation Series controller or V Series controller
- Drives can directly exchange data between themselves (4 words)
- Fiber-optic bus in a star configuration
- 2 Mbps peer-to-peer protocol; bus scan time based on the number of nodes:

Quantity of Nodes	Bus Scan Time
2-3	1 ms
4-5	2 ms
6-8	4 ms
9-64	25 ms



### ISBus

- Supports both run-time control (10 words in and 10 words out) and Toolbox configuration/monitoring using the Innovation Series controller as a gateway between the ISBus and Ethernet
- RS-485 or optional fiber-optic bus in a synchronous ring configuration
- 5 Mbps master/follower (drive is the follower) protocol using copper or fiber; bus scan time based on the number of nodes:

Quantity of Nodes	Bus Scan Time
2-4	1 ms
5-8	2 ms
6-16	4 ms
17-32	8 ms



### Modbus

- Supports run-time control (fixed 10 words in/out) from a Modbus-RTU controller
- RS-485 copper bus
- 1.2 kbps to 57.6 kbps master/follower protocol; update rates up to 20 ms/node possible at the highest baud rate
- Number of nodes: 127 max per LAN



### Profibus-DP™

- Supports run-time control (6 words in and out) from a Profibus-DP master controller
- Copper bus in a daisy-chain configuration
- 9.6 kbps to 12 Mbps master/follower protocol; bus scan time based on the number of nodes



### DeviceNet™

- Supports run-time control (4 words in and 10 words out) from a DeviceNet master controller
- Copper bus in a daisy-chain configuration
- 125 kbps to 500 kbps master/follower protocol; bus scan time based on the number of nodes

Note: 1 word = 16 bits

# Operator Interfaces

## Standard Display (Inverters and Regenerative Converters)

Three-digit display alternates between speed and current while running, or a fault code when there is an error.



Optional analog meters can be supplied in addition to either the standard or enhanced display. Up to four meters can be provided.



Three LEDs give a quick indication of the status of the unit



RJ-45 Ethernet port is used for local toolbox connection

Interlock button disables the drive

### LED Indication

Ready	On when the unit is ready to run
Running	On when the unit is running
Alarm/Fault	Blinking LED indicates alarm condition, while solid LED indicates a fault

## Keypad Option (Inverters and Regenerative Converters)

### High Function Display

- LCD backlight gives great visibility and long life
- Bar graphs, icons, menus, and digital values combine to provide concise status information, often eliminating the need for traditional analog meters



Easy-to-understand navigation buttons allow quick access to information without resorting to a PC-based tool

Switch to local mode and operate the equipment right from the keypad

RJ-45 Ethernet port is used for the local toolbox connection

### Instrumentation Interface

- Two analog outputs are dedicated to motor current feedback
- Five analog outputs can be mapped to variables for external data logging and analysis

Interlock button disables the drive

# TMEIC AC Drives Offer Complete Coverage

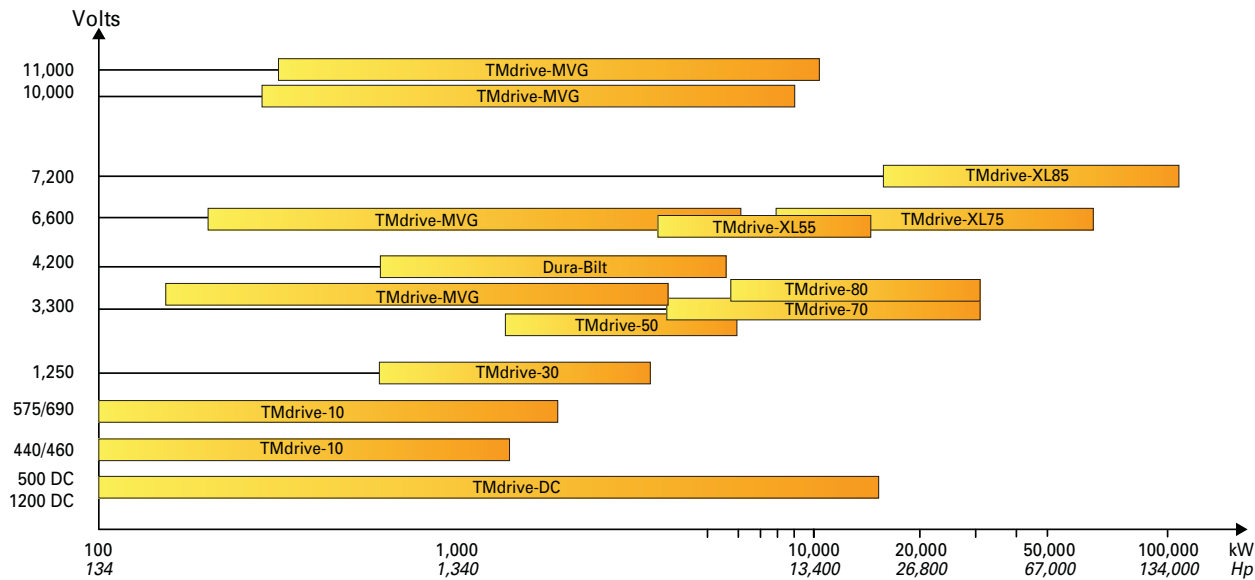

Global Office Locations:

## TMEIC Corporation

Office: 1325 Electric Road, Roanoke, VA, 24018, USA  
 Mailing: 2060 Cook Drive, Salem, VA, 24153, USA  
 Tel.: +1-540-283-2000; Fax: +1-540-283-2001  
 Email: info@tmeic.com; Web: www.tmeic.com

## TMEIC Corporation - Houston Branch

2901 Wilcrest Dr., Houston, TX 77042, USA  
 Tel.: +1-713-784-2163; Fax: +1-713-784-2842  
 Email: OilGas@tmeic.com; Web: www.tmeic.com

## TMEIC Power Electronic Products Corporation

13131 W. Little York Road, Houston, Texas 77041, USA

## Toshiba Mitsubishi-Electric Industrial Systems Corporation

Tokyo Square Garden  
 3-1-1 Kyobashi, Chuo-kyo, Tokyo, 104-0031, Japan  
 Tel.: +81-0-3327-5511  
 Web: www.tmeic.co.jp

## TMEIC Europe Limited

6-9 The Square, Stockley Park, Uxbridge, Middlesex,  
 United Kingdom, UB7 7LT  
 Tel.: +44 870 950 7220; Fax: +44 870 950 7221  
 Email: info@tmeic.eu; Web: www.tmeic.com/Europe

## TMEIC Industrial Systems India Private Limited

Unit # 03-04, Third Floor,  
 Block 2, Cyber Pearl, HITEC City, Madhapur,  
 Hyderabad, 500081, Andhra Pradesh, India

Tel.: +91-40-44434-0000; Fax: +91-40-44434-0034  
 Email: inquiry\_india@tmeic.com; Web: www.tmeic.in

## Toshiba Mitsubishi-Electric Industrial Systems Corp (Beijing)

21/F, Building B, In.do Mansion, 48 Zhichunlu A, Haidian District, Beijing 100098, PRC  
 Tel.: +86 10 5873-2277; Fax: +86 10 5873-2208  
 Email: sales@tmeic-cn.com

## TMEIC – Sistemas Industriais da América do Sul Ltda.

Av. Paulista, 1439 cj72  
 Bela Vista, CEP:01311-200  
 São Paulo/SP, Brasil  
 Tel: +55-11-3266-6161; Fax: +55-11-3253-0697

Innovation Series is a trademark of General Electric Company.  
 TMdrive is a registered trademark of TOSHIBA MITSUBISHI-ELECTRIC INDUSTRIAL SYSTEMS CORPORATION.  
 TMEIC is a registered trademark of TOSHIBA MITSUBISHI-ELECTRIC INDUSTRIAL SYSTEMS CORPORATION.

*All other products mentioned are registered trademarks and/or trademarks of their respective companies.*

*All specifications in this document are subject to change without notice. The above brochure is provided free of charge and without obligation to the reader or to TMEIC Corporation. TMEIC Corporation does not accept, nor imply, the acceptance of any liability with regard to the use of the information provided. TMEIC Corporation provides the information included herein as is and without warranty of any kind, express or implied, including but not limited to any implied statutory warranty of merchantability or fitness for particular purposes. The information is provided solely as a general reference to the potential benefits that may be attributable to the technology discussed. Individual results may vary. Independent analysis and testing of each application is required to determine the results and benefits to be achieved from the technology discussed. If you have any questions regarding your project requirements, please contact TMEIC Corporation at 540-283-2000.*