



TMdrive[®]-XL55 Product Guide

Medium Voltage Multilevel IGBT Drive
Up to 16,000 kVA at 6.6 kV

metals

cranes

mining

testing

oil & gas

renewable
energy









power
generation

cement

Global Products for Meeting Global Needs

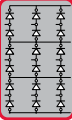
The TMdrive-XL55 is a medium-voltage, variable-frequency AC drive for industrial power ratings up to 16 MVA, in the voltage range of 6.0-6.6 kV. Featuring high-quality design and manufacture, the water cooled TMdrive-XL55 provides high reliability, low harmonic distortion, and meets users' basic system requirements as described below:



Design Feature	Customer Benefit
 <ul style="list-style-type: none"> • Conservative design using 4500 Volt IGBTs (Insulated Gate Bipolar Transistor) 	<ul style="list-style-type: none"> • Highly reliable operation and expected 87,000 hour (10-year) drive MTBF, based on field experience with over 700 medium voltage drive installations
 <ul style="list-style-type: none"> • High energy efficiency of approximately 98.6% 	<ul style="list-style-type: none"> • Considerable energy savings
 <ul style="list-style-type: none"> • Diode rectifier ensures power factor greater than 95% in the typical speed control range 	<ul style="list-style-type: none"> • Capacitors are not required for power factor correction
 <ul style="list-style-type: none"> • Multiple level drive output waveform to the motor (five levels) 	<ul style="list-style-type: none"> • Smooth output voltage, motor friendly wave form
 <ul style="list-style-type: none"> • 36-pulse converter rectifier using separated phase shifted transformer 	<ul style="list-style-type: none"> • No harmonic filter required to provide lower harmonic distortion levels than IEEE-519-1992 guidelines
 <ul style="list-style-type: none"> • Designed to keep running after utility supply-transient voltage dropouts – up to 300 msec. 	<ul style="list-style-type: none"> • Uninterrupted service for critical loads
 <ul style="list-style-type: none"> • Externally mounted input isolation transformer 	<ul style="list-style-type: none"> • Less power loss in drive room • Less total space required • Simplified design and installation
 <ul style="list-style-type: none"> • 6.6 kV direct drive voltage output level 	<ul style="list-style-type: none"> • No output transformer required, saving cost, mounting space, and energy

Bringing Reliable Control to a Wide Variety of Industries



Oil and Gas

In the Oil and Gas Industry, the TMdrive-XL55 is designed for driving large compressors on pipeline and in LNG plants. Applications include:

- Gas compressors
- Fans and blowers
- Oil and water pumps



Mining

Accurate torque control is a key in controlling large conveyors. The TMdrive-XL55's flux vector algorithm provides the accuracy and response for this demanding application. Mining applications include:

- Raw material conveyors
- Grinding mills
- Pumps



Utilities/Power Generation

Traditional mechanical methods of controlling flow are inefficient and require considerable maintenance. In the Power Generation industry, the TMdrive-XL55 provides more reliable, accurate, and energy-efficient control of flow while eliminating the maintenance associated with dampers, vanes, or valves on:

- Induced and forced draft fans
- Primary and secondary air fans
- Boiler feed water pumps
- Condensate extraction pumps



Cement

The TMdrive-XL55's compact design streamlines installation, commissioning, and maintenance of medium-voltage drives in the cement industry. With a Mean Time Between Failure (MTBF) exceeding 87,000 hours (10 years), the TMdrive-XL55 is engineered to deliver rock-solid performance in virtually any application, making it a best choice of many consultants, end users, and cement plant builders. Applications include:

- Raw mill fans, bag house fans
- Preheater fans, coal mill fans
- Grinding mills
- Rotary kilns



Metals

The metal-making part of the steel plant uses large air flows and requires high power levels supplied by the TMdrive-XL55 to operate:

- Water gas fans
- BOF ID fans
- Dust collection fans
- Blast furnace blower fans
- Utility pumps

A Look on the Inside

Medium Voltage, Pulse Width Modulated, Drive Technology

- Diode bridge rectifiers yield high power factor operation
- Draw out phase modules minimize service time
- Efficient water cooling yields small footprint

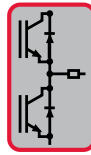

Inverter Modules

- Six draw out modules
- Neutral point clamped circuits
- Five-level voltage for motor friendly output

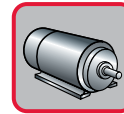

Output Cabinet

- Motor cable terminals
- Three current transformers

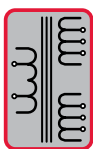

Main Power Input

- Air cooled phase shifted transformer is separated
- Three sets of two inputs at 1930 Vac



Diode Converter Modules

- Three draw-out modules
- Supply DC power busses at 5000 Vdc

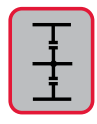

DC Bus Cabinet

- Three busses
- Six large power storage capacitors



Water Cooling Input

- Separate water cooling cabinet with redundant pumps (page 6)
- De-ionized water circulated through power unit

Back of Cabinets

Power Output Cabinet Inverter Cabinets

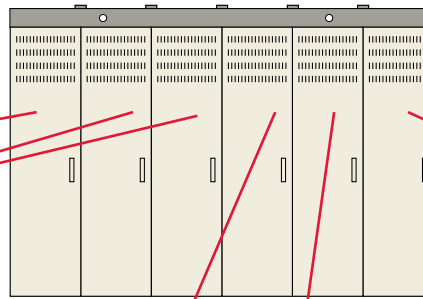

DC Bus Cabinet

Diode Converter Cabinet

Power Input

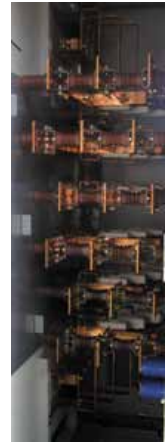

Inverter Module Removed from Rack



Switching Devices

Switching devices are Insulated Gate Bipolar Transistors (IGBT)

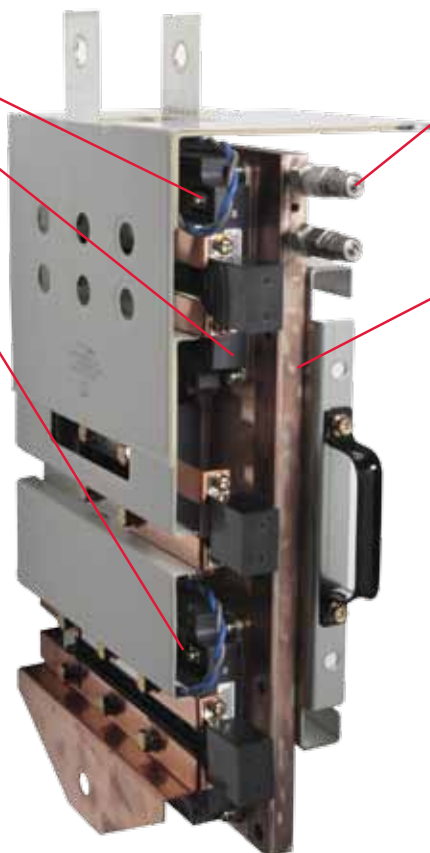

Water Cooling Connections

Deionized water circulates through cooling plate



Cooling Heat Sink

Heat is transferred from the switching devices to the cooling plate

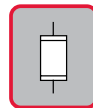

Input Fuse

Fused three-phase inputs to converter

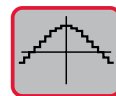

Control Board

- Board passes Pulse Width Modulated control signal to the gate drivers
- Gate driver circuit boards connect directly to IGBTs

Water Conditioning Equipment

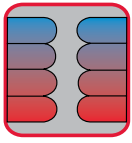

Water conditioning control panel continuously monitors the status of the water system. Separate fault indications help find and fix problems fast.

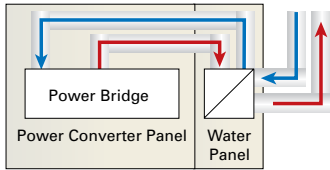

Integrated water system has internal plumbing for de-ionized cooling loop.

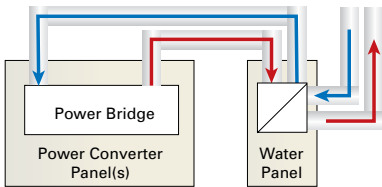

Separate type cooling has field-installed plumbing for de-ionized cooling loop. Separate cooling can use a water-to-air heat exchanger; this requires special engineering.

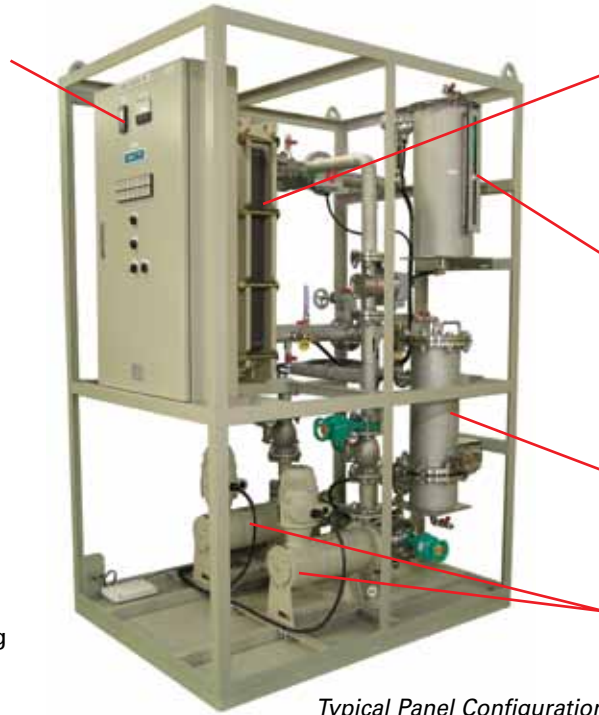

Typical Panel Configuration

Water to water heat exchanger keeps the de-ionized system isolated from the plant water supply.

Surge tank absorbs water during pump transients and indicates the internal cooling loop water level.

De-ionizer removes contaminants for the internal cooling loop.

Redundant pumps keep the system running even if one pump fails

Type	Heat Exchange Capacity	Width mm (in)	Depth mm (in)	Height mm (in)	Weight kg (lbs)	Power Supply kVA	Notes
Single Bank Drive	60 kW	1200 (48)	1300 (52)	2375 (94)	1600 (3527)	7	Capacity for one bank. Plant water required: 111 l/min (30 gal/min)
Twin Bank Drive	120 kW	1200 (48)	1300 (52)	2375 (94)	1650 (3638)	9	Capacity for two banks. Plant water required: 222 l/min (60 gal/min)

Inlet Cooling Water Temperature Requirements & Power Derating

TMdrive-XL55	Maximum Water Temperature C(°F)	
	One Bank	Two Banks
Cooling water supplied by plant (Industrial water)	32 (90)	32 (90)
Cooling, de-ionized water flowing through the power unit (Pure water)	40 (104)	40 (104)
Cooling, de-ionized water flowing through the power unit (Pure water) - Alarm	41 (106)	41 (106)
Cooling, de-ionized water flowing through the power unit (Pure water) - Fault	43 (109)	43 (109)

Industrial Water Temperature at the cooler inlet	
Temperature - C(°F)	Output Current De-rating Factor
32 (90)	1.000
35 (95)	0.957
40 (104)	0.883
45 (113)	0.807

Pure Water Temperature at the cooler exit	
Temperature - C(°F)	Output Current De-rating Factor
20 (68)	1.00
30 (86)	1.00
40 (104)	1.00
45 (113)	0.94

Synchronous Motor Field Supply

Field Excited – DC Excitation						
Supply Voltage	Class	Frame Size	Cabinet Type	Rated kW	Rated Voltage dc	Rated Amps dc
460 V	200 A	D40	A1	37	460	80
	200 A	D80	A1	74	460	160
	200 A	D110	A1	110	460	240
	400 A	D200		207	460	450
	1000 A	D280	A3	276	460	600
	1000A	D450	A3	442	460	960
	1000 A	D550	A4	544	460	1183
690 V	1000 A	D400	A3	414	690	600
	1000 A	D660	A3	662	690	960
	1000 A	D820	A4	816	690	1183

Field Excited – AC Excitation						
Supply Voltage	Class	Frame Size	Cabinet Type	Rated kW	Rated Voltage dc	Rated Amps dc
460 V	200 A	A50	A1	52	460	65
	200 A	A100	A1	104	460	130
	200 A	A150	A1	156	460	196
	400 A	A200		194	460	244
	400 A	A300		297	460	373
	1000 A	A400	A3	390	460	489
	1000 A	A600	A3	624	460	783
690 V	1000 A	A800	A4	765	460	966
	1000 A	A580	A3	584	690	489
	1000 A	A900	A3	936	690	783
	1000 A	A1200	A4	1154	690	966

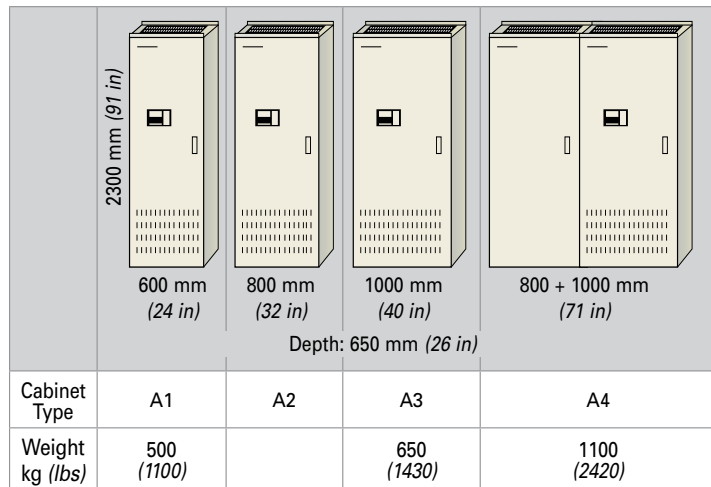

2100 Frame Field Supply

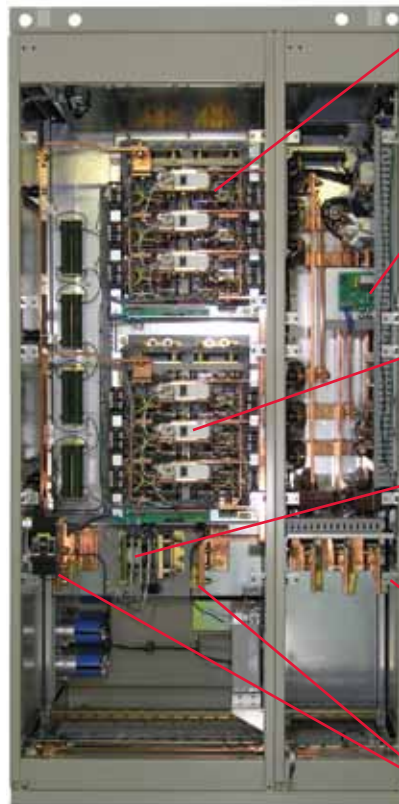

Main Power module. One module is applied for the 1200A supply and two modules for the 2100A model.

Ground Fault detection module provides indication of insulation failure

AC Leg Fuses protect power bridge from faults on the ac line

Autonomous Crowbar prevents dangerous motor voltages from developing under certain fault conditions

AC Connection Bus. AC voltages up to 500 Vac can be connected depending on required voltage.

DC Field Connection Bus

Notes

- $$kVA_{Inverter} = \frac{\text{Power}_{Mtr Shaft}}{\text{Mtr PF} \times \text{Mtr Eff}}$$

$$I_{Phase} = \frac{kVA_{Inverter}}{V_{Mtr Line to Line}} \times (1000) / (1.732) \times$$
 - Mtr PF – 0.87, Mtr Eff = 0.94, ambient temperature is 32°F–104°F (0°C–40°C).
 - Ratings based on a variable torque load (industrial fans and pumps).
 - For constant torque load applications, a de-rate factor should be applied. Consult TMEIC Application Center.
 - Altitude above sea level is 0–3300 ft (0–1000 m).

- An optional bypass circuit can be separately mounted.
- Incoming power cabling and motor cabling are bottom entry; top entry is an option.
- Air is pulled in through the filters in the cabinet doors and vented out the top.
- Options include motor cooling fans and control, cabinet space heater, bypass power/control and dv/dt filter, HV input, sync motor control, bumpless transfer to and from utility.

TMdrive-XL55 Architecture

The drive architecture is modular for simplified maintenance, consisting of three diode converters and six inverter modules.

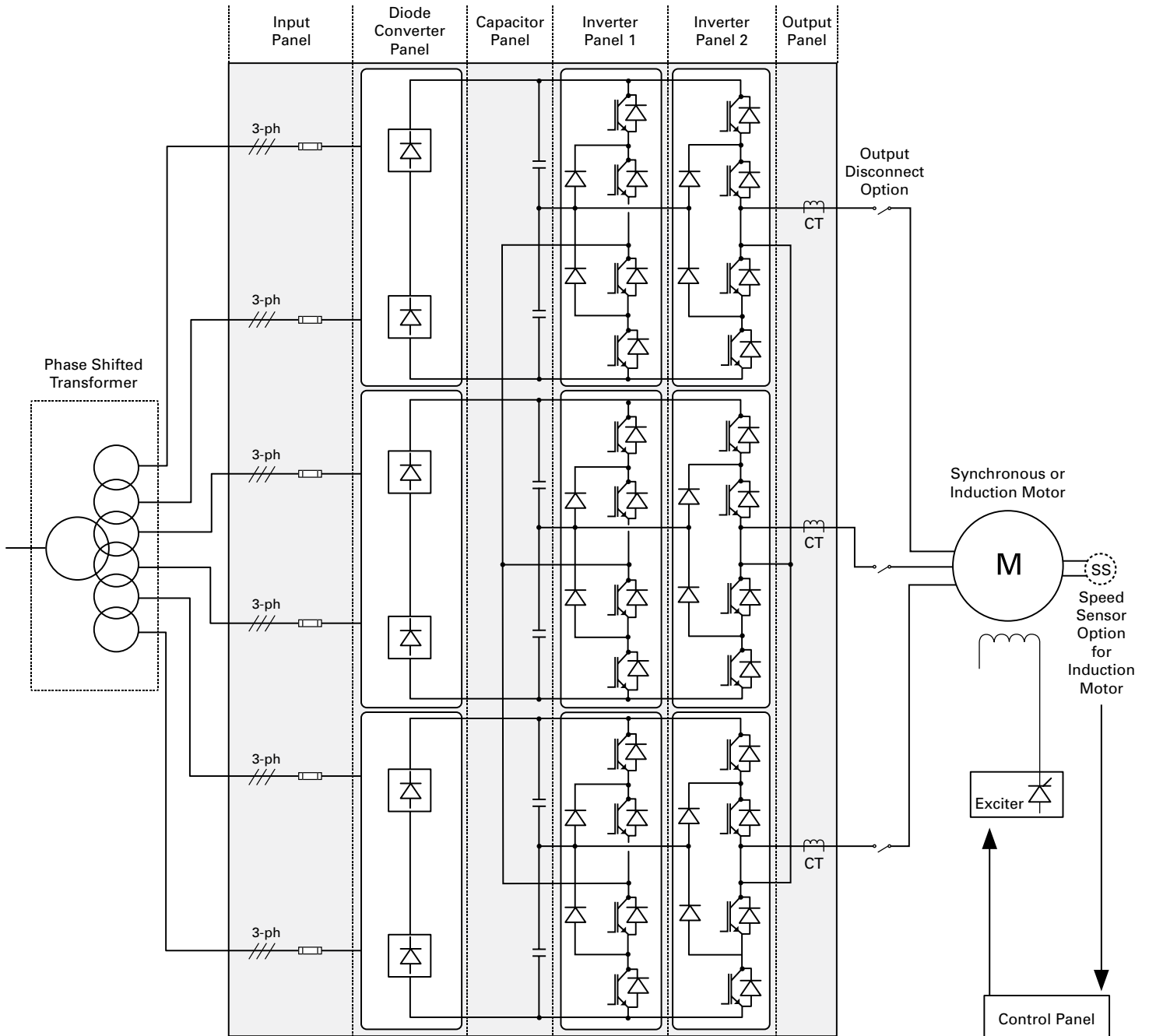

TMdrive-XL55 Two-Bank Architecture

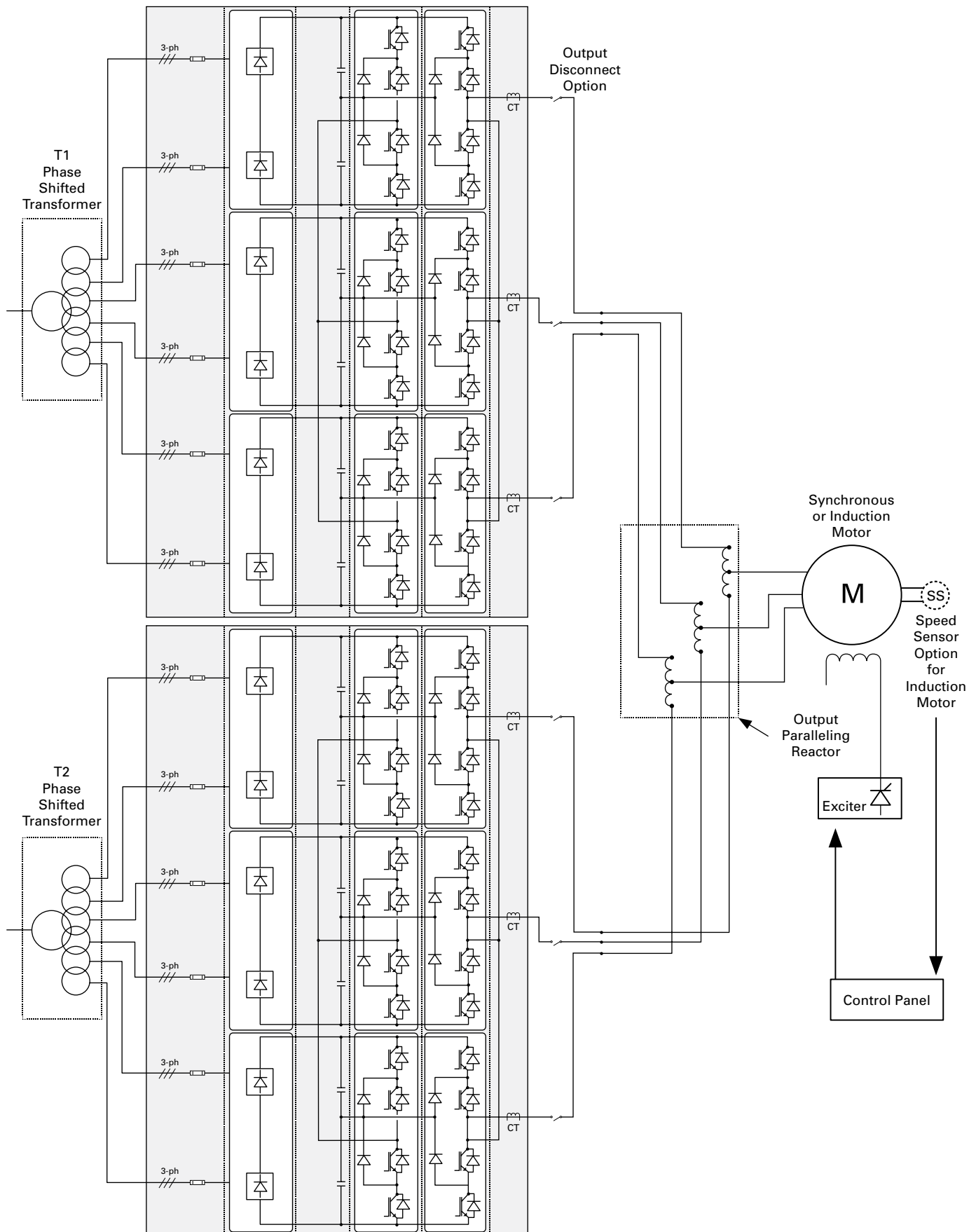

TMdrive-XL55 Specifications

TMdrive-XL55 Single Bank Cabinet Line-Up

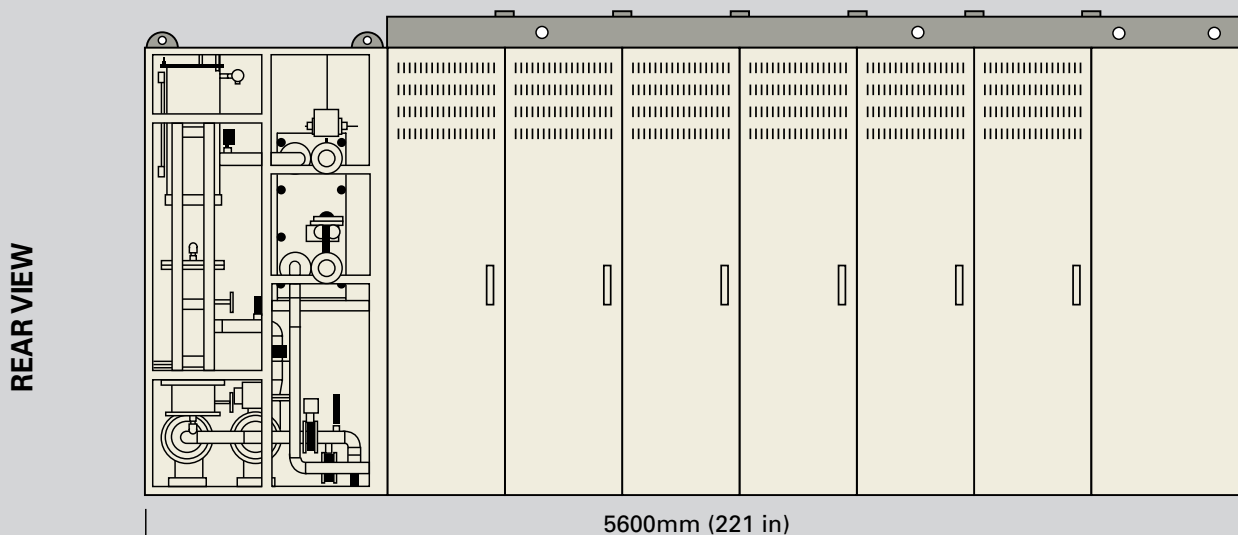
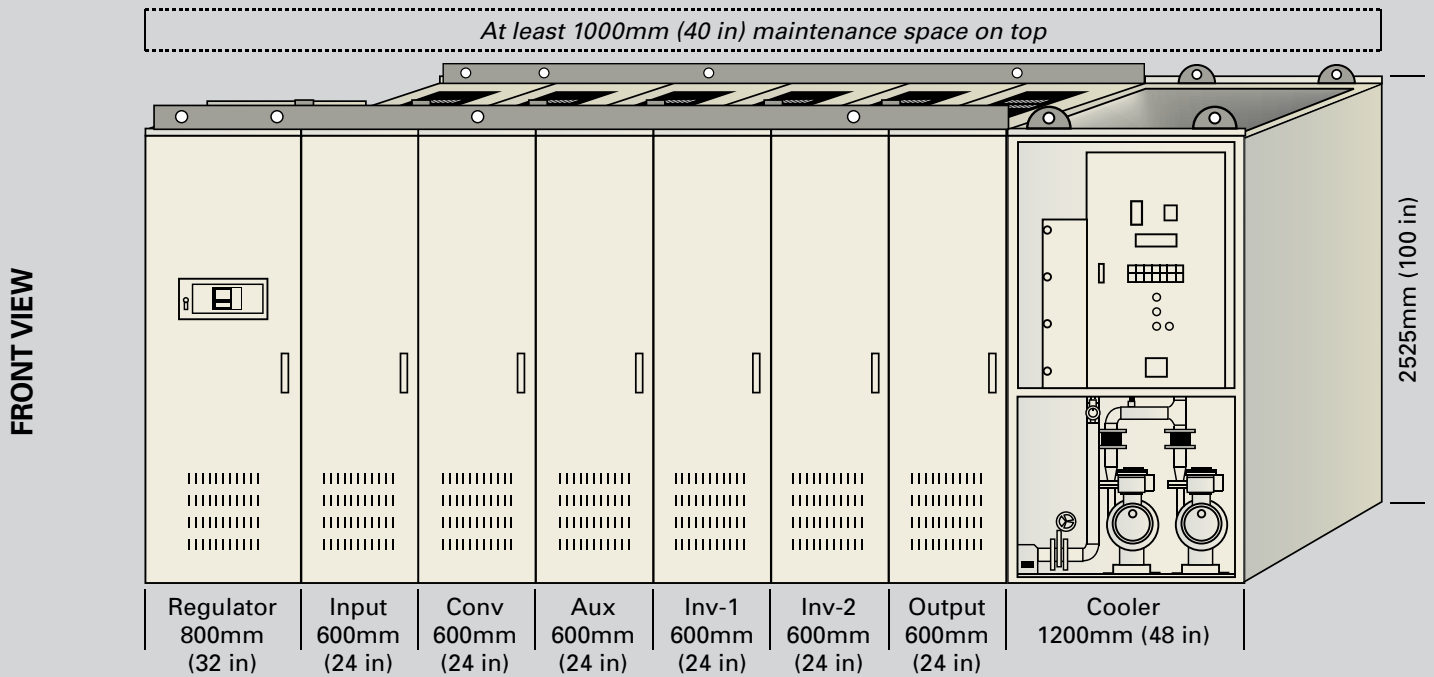
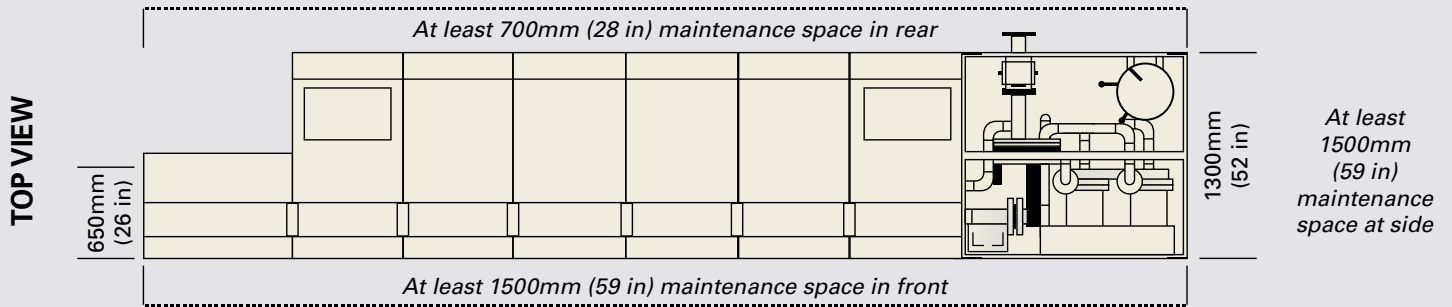

Notes: for overload ratings and power Calculations, see page 11

TMdrive-XL55 Dual Bank Line-Up

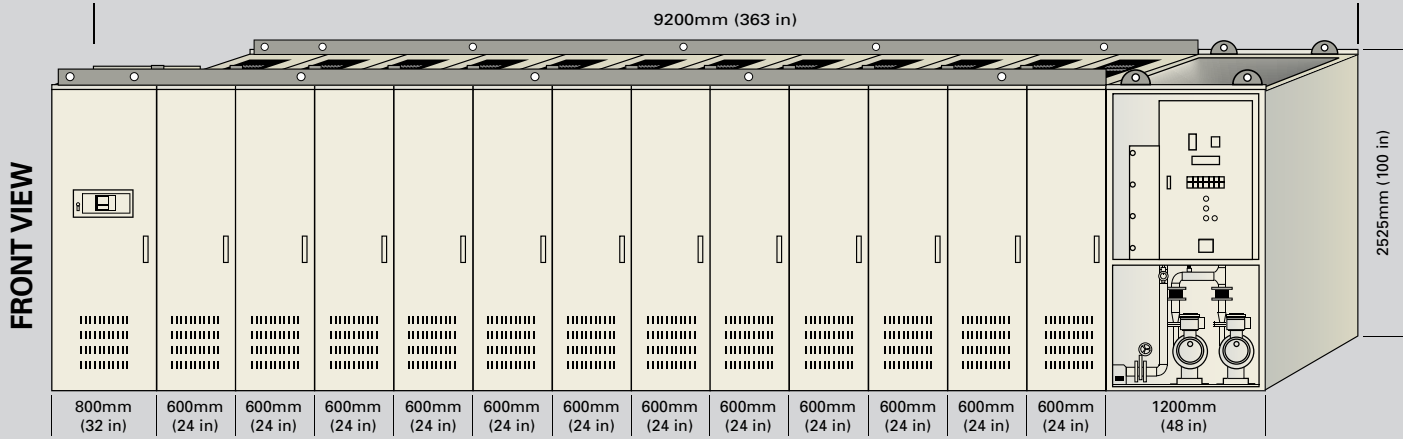
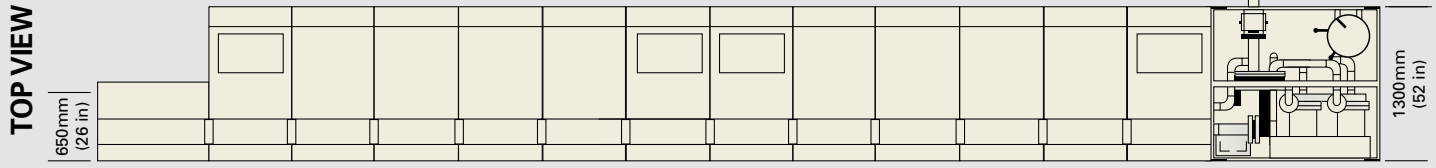

Drive Specifications

	Rated Output Current Amps	Out Power kVA	Approx. Motor Power HP*	Approx. Motor Power KW*	Weight kg (lbs)
Single Bank Drive	700	8000	8667	6488	7200 (15840)
Dual Bank Drive	1400	16000	17334	12976	12200 (26840)

* Approximate capacity for 6.6kV-based 6-pole induction motors with typical efficiency (0.94) and power factor (0.87)

Features of the TMdrive-XL55

A Clean Wave Inverter

Using the multiple winding input transformer and 36-pulse diode rectifier, the TMdrive-XL55 creates low harmonic voltage distortion of the power source. The harmonic current content is less than the IEEE-519 standard as shown in the chart opposite, protecting other equipment in the plant.

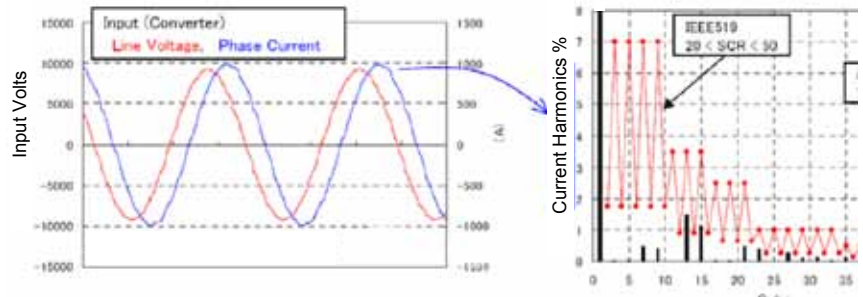

Drive Input Wave forms

Input Current Harmonics

A Clean Output Wave

As a result of the five-level PWM control, the output current waveform is close to a sine wave, and the heat loss in the windings caused by harmonics is negligible. In addition, harmonic currents in the motor are minimized so there is very little torque ripple on the output shaft and very little risk of torsional load resonance.

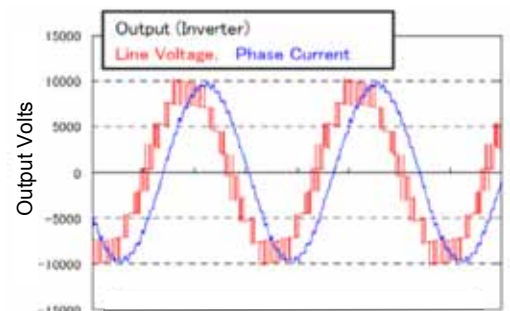

Inverter Output Waveforms
(Simulation, include inverter with LR load)

A Higher Efficiency than Conventional Drives

Actual factory load tests show the drive efficiency is approximately 98.6% (design value). This high efficiency is a result of:

- A smaller number of switching semiconductors by using 4500 V IGBTs
- Lower switching frequencies using multilevel PWM control reduce the switching loss of each IGBT
- Direct connection of MV motor without an output transformer

A High Input Power Factor

As a result of the diode bridge rectifier, the input power factor is above 95% over the entire normal operating speed range, even when driving a multiple-pole induction motor of low power factor. With this high power factor, no power factor correction capacitor is required.

Common Control Boards to Reduce Cost of Ownership

Standard Connections

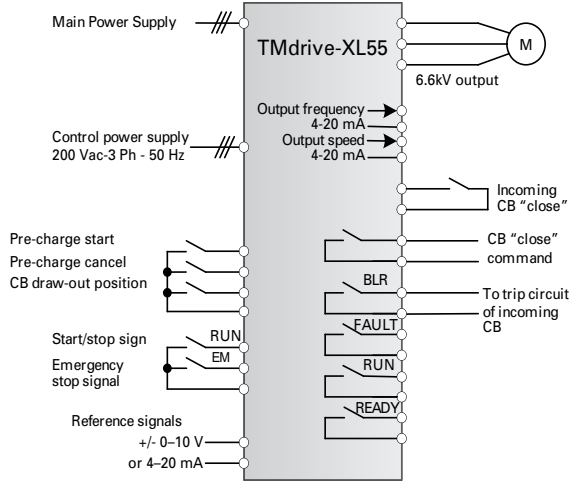

Control I/O

Control Area	Specifications
Analog Inputs	(2) ± 10 V or 4–20 mA, configurable, differential
Analog Outputs	(4) ± 10 V, 8-bit, configurable, 10 mA max
Digital Inputs	(2) 24–110 V dc or 48–120 V ac; (6) 24 V dc, configurable
Digital Outputs	(6) 24 V dc open collector 50 mA
Speed Feedback Encoder Input	High-resolution tach, 10 kHz, 5 or 15 V dc diff. input, A Quad B, with marker
LAN Interface Options	Profibus-DP, ISBus, DeviceNet™, TOSLINE®-S20, or Modbus RTU
Motor Temperature Sensor	High-resolution torque motor temperature feedback: 1 K Ohm platinum resistor or 100 Ohm platinum RTD (uses analog input with signal conditioner)

Mechanical Specifications

Operating Environment and Needs

- Temperature: 0° to +40°C
- Humidity: 95% maximum, noncondensing
- Altitude: Up to 1000 m (3300 ft) above sea level
- Fan/pre-charge Power (by user): 380/400/440 Vac, 3 phase, 50 Hz or 60 Hz

Cooling

- Water-cooled with fans on top
- Temperature of industrial cooling water: 0–32°C at cooler inlet, 0–45°C with derating

Sound

- Less than 75 dBA, at 3.1 ft (1 m) from enclosure

Vibration

- 10 to 50Hz, 0.5G or less
- IEC61800-4 5-1-22

Enclosure

- IP42 except for fan openings (IEC 60529), NEMA1 gasketed equivalent
- Color: Munsell 5Y7/1 (Option: ANSI 61 gray, RAL7032 etc.)
- Air filter on front and rear door, can replace with door closed

Additional Specifications

Power System Input and Harmonic Data

- Voltage: 3 x 2 x 1930 Vac, 3-phase, $\pm 10\%$
- 100% continuous load, no overload
- Main circuit withstand voltage: 17kV for one minute
- Frequency: 50 Hz or 60 Hz, $\pm 2\text{Hz}$
- Displacement power factor (PF): 0.95 lag
- True PF: greater than 0.95 lag over 40–100% speed range
- Better than the IEEE 519-1992 standard for harmonics, without filters
- Bottom cable entry, top entry option
- Cooler Power: 380V - 50Hz; 400V - 50/60Hz; 440V - 60Hz; other options

Converter Type

- AC-fed multi-pulse diode using phase shifted transformer
- DC bus voltage: 3 x 5000 Vdc

Inverter

- Five-level inverter for motor friendly wave form
- Motor voltage: 6600 or 6000 Vac
- Rated frequency: 50/60Hz
- 250Hz, for over 75Hz consult TMEIC

Applicable Standards

- IEC61800-4, JIS, JEC, JEM, C€(option), CSA (option)

Control

- Nonvolatile memory for parameters and fault data
- Vector control with or without speed feedback, or Volts/Hz control with slip compensation for IM
- Synchronous transfer to line option
- Synchronous motor control (option)

Protective Functions

- Inverter overcurrent, overvoltage
- Low or loss of system voltage
- Motor ground fault
- Motor overload
- Cooling fan abnormal
- Over-temperature
- CPU error

Display and Diagnostics

	Specifications
PC Configuration	Control System Drive Navigator for configuration, local and remote monitoring, animated block diagrams, dynamic live and capture buffer based trending, fault diagnostics, commissioning wizard, and regulator tune-up wizards. Ethernet 10 Mbps point to point or multi-drop, each drive has its own IP address
Keypad and Display	Backlit LCD, animated displays <ul style="list-style-type: none"> • Parameter editing • Four configurable bar graphs • Drive control
Instrumentation Interface	Two analog outputs dedicated to motor current feedback, plus five analog outputs that can be mapped to variables for external data logging and analysis

Operator Interfaces

Keypad Option (Inverters and Regenerative Converters)



High Function Display

- LCD backlight gives great visibility and long life
- Bar graphs, icons, menus, and digital values combine to provide concise status information, often eliminating the need for traditional analog meters

RJ-45 Ethernet port is used for the local toolbox connection

Instrumentation Interface

- Two analog outputs are dedicated to motor current feedback
- Five analog outputs can be mapped to variables for external data logging and analysis

Interlock button disables the drive

Switch to local mode and operate the equipment right from the keypad

Easy-to-understand navigation buttons allow quick access to information without resorting to a PC-based tool

Drive Navigator – Configuration, Monitoring & Analysis

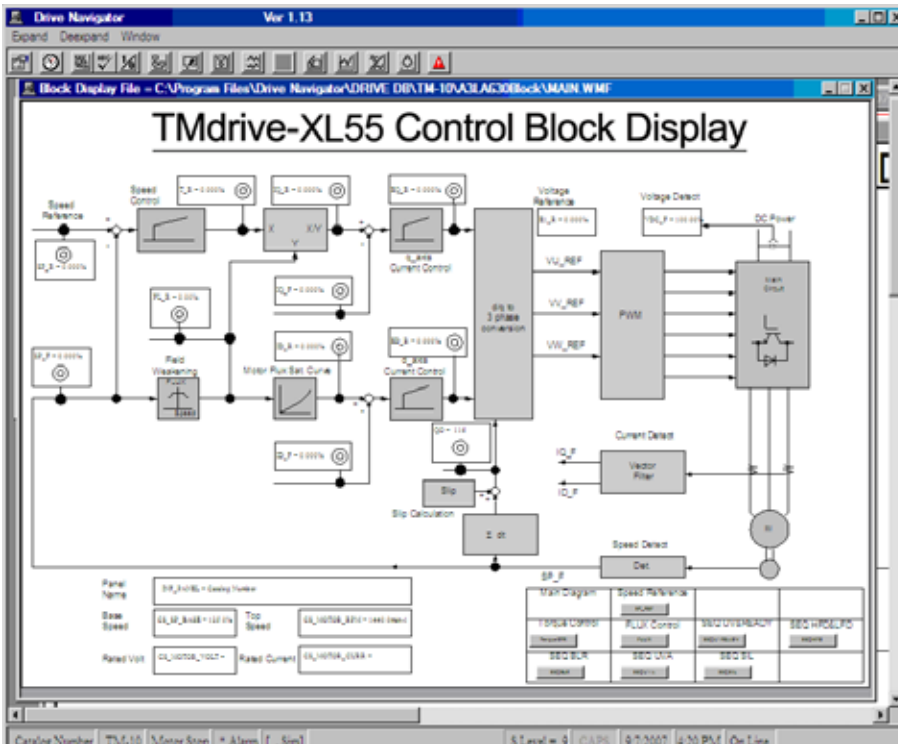

Real-Time Drive Block Diagram

Drive Configuration

All the TMdrive family of drives are configured and commissioned with the Windows-based Drive Navigator. Wizards intelligently guide the user through the required steps. The Navigator features live block diagrams, highly integrated help, and high-performance diagnostics. Several sets of drives can be maintained using Ethernet communication. The control block display opposite shows the main drive control functions together with real-time values of the important variables. Available Navigator functions include:

Parameter (Set Point) Control

- Loading and saving a parameter file
- Changing a parameter
- Comparing parameter files

Support Functions

- Control block display
- Snapshot function
- Step response test
- Response wave display

Drive Troubleshooting

This screen displays a drive first fault and shows selected trend displays to assist in determining the cause. The fastest trend displays four variables sampled at a rate of 333 microseconds. The other two slower trends are sampled at 1 millisecond and 100 milliseconds.

Available Troubleshooting Functions:

- First fault display
- Operation preparation display
- Fault trace back
- Trouble records
- Fault history display
- Online manual

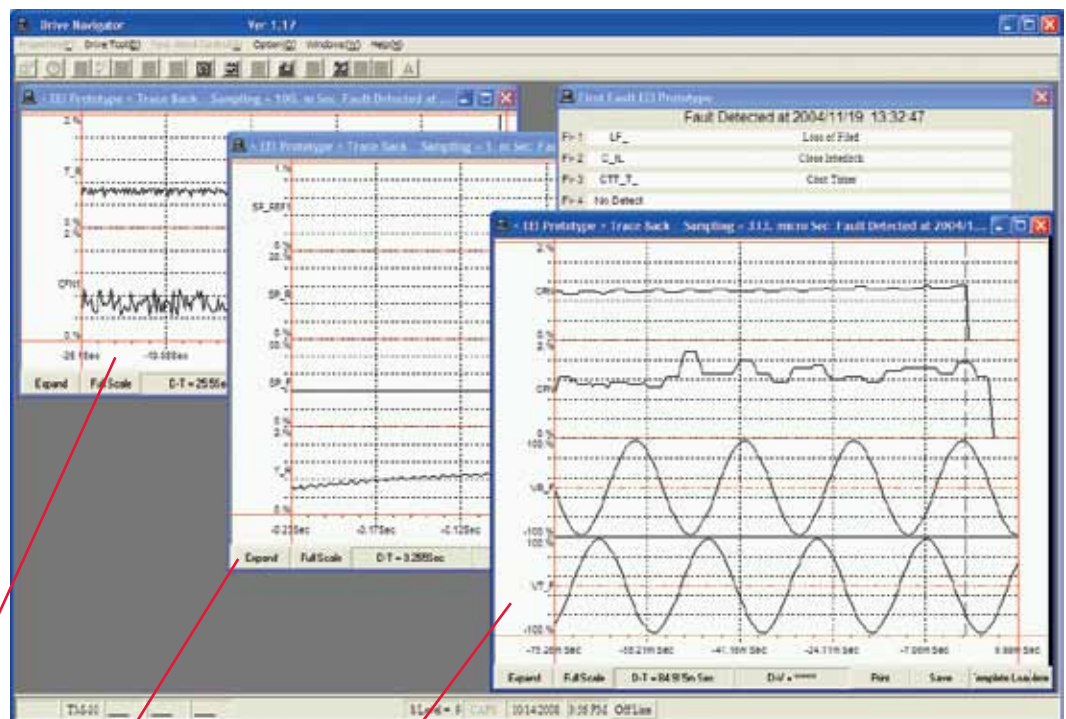

100 msec. sampling

1 msec. sampling

Sub-millisecond sampling

TMEiC Drives Offer Complete Coverage

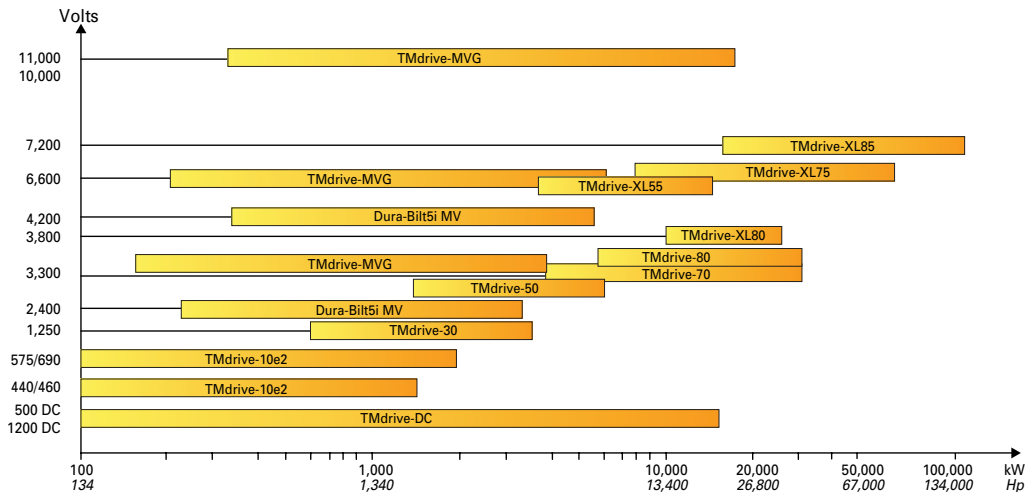

Global Office Locations:

TMEiC Corporation

Office: 1325 Electric Road, Suite 200
Roanoke, VA, United States 24018

Mailing: 2060 Cook Drive
Salem, VA, United States 24153

Tel.: +1-540-283-2000

Fax: +1-540-283-2001

Email: GI@tmeic.com

Web: www.tmeic.com

TMEiC Houston

2901 Wilcrest Drive, Suite 110
Houston, TX, United States 77042

Email: OilGas@tmeic.com

Web: www.tmeic.com

TOSHIBA MITSUBISHI-ELECTRIC INDUSTRIAL SYSTEMS CORPORATION

Tokyo Square Garden
3-1-1 Kyobashi, Chuo-kyo Tokyo

104-0031 Japan

Tel.: +81-3-3227-5511

Web: www.tmeic.co.jp

Shanghai TMEiC Electric Drive Technology Co.

Rm 2901, Shanghaimart, 2299 Yan'An Rd. (W),
Changning District, Shanghai 200336, P.R. China

Tel.: +86-21-6236-0588 ex 717

Fax: +86-21-6441-3019

TMEiC Asia Company Limited

152 Beach Road #16-00 Gateway East, Singapore 189721

Tel.: +65-6292-7226

Fax: +65-6292-0817

TMEiC Europe Limited

6-9 The Square, Stockley Park
Uxbridge, Middlesex, United Kingdom
UB11 1FW

Tel.: +44 870 950 7220

Fax: +44 870 950 7221

Email: info@tmeic-eu.com

Web: www.tmeic.com

TMEiC Industrial Systems India Private Limited

Unit 03-04, Third Floor,
Block 2, Cyber Pearl, HITEC City, Madhapur,
Hyderabad, 500081, Andhra Pradesh, India

Tel.: +91-40-4434-0000

Fax: +91-40-4434-0034

Email: inquiry_india@tmeic.in

Web: www.tmeic.in

TOSHIBA MITSUBISHI-ELECTRIC INDUSTRIAL SYSTEMS (BEIJING) CORP.

21/F, Building B, In.do Mansion
48 Zhichunlu A, Haidian District,
Beijing 100098, PRC

Tel.: +86 10 5873-2277

Fax: +86 10 5873-2208

Email: sales@tmeic-cn.com

TMdrive is a registered trademark of TOSHIBA MITSUBISHI-ELECTRIC INDUSTRIALSYSTEMS CORPORATION.

All other products mentioned are registered trademarks and/or trademarks of their respective companies.

All specifications in this document are subject to change without notice. This brochure is provided free of charge and without obligation to the reader or to TMEiC Corporation, and is for informational purposes only. TMEiC Corporation does not accept, nor imply, the acceptance of any liability with regard to the use of the information provided. TMEiC Corporation provides the information included herein as is and without warranty of any kind, express or implied, including but not limited to any implied statutory warranty of merchantability or fitness for particular purposes. The brochure is not an implied or express contract.