

## Crane Control and Automation Global Solutions

metals

**cranes**

mining

testing

oil & gas

paper

utilities

cement

## Organization of Document

TMEiC designs, tests, and commissions complete crane automation systems. This document provides an overview of the engineering processes and technology used in these systems. The figures below illustrate these processes and technologies with each section identified with a numbered page icon (#).

### Comprehensive Engineering Process

A smooth crane system startup depends on a well-planned and executed engineering process. Starting with the system proposal and specification, TMEiC's application engineers manage the entire project through commissioning. This critical engineering process is illustrated below and detailed in the Project Engineering section. Icons indicate where the various teams of engineers in the factory and field service organizations are involved in the project.

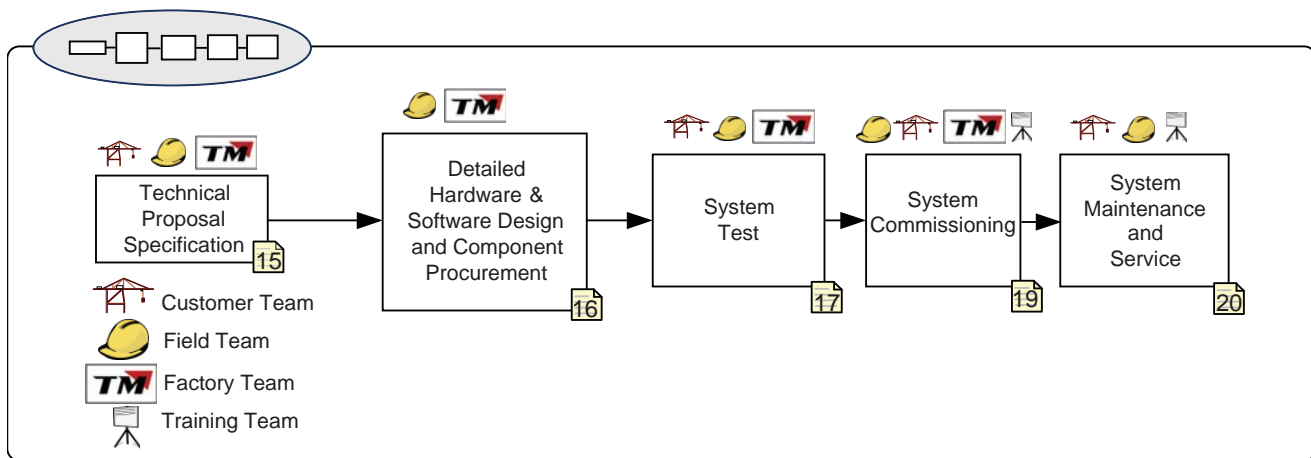

*Project Engineering Process*

### A Flexible Control System Architecture

The Maxspeed® crane control system architecture uses a master controller to coordinate all the networked drives and to communicate with the operator interfaces, input/output devices, and the yard management system. The Maxview® system employs vision systems to automate the crane operation. TMEiC has adopted industry standards to simplify the configuration and integration of these complex control systems for your application:

- Globally-accepted communication protocols and open data interfaces for seamless integration of third-party systems, and maximum flexibility for future growth and minimum risk of obsolescence
- Ethernet® communications between the controller, operator interfaces, and yard management, providing high-speed communication and low-cost, standard spare parts availability
- Windows®-based configuration tools, familiar to all users, for all system components

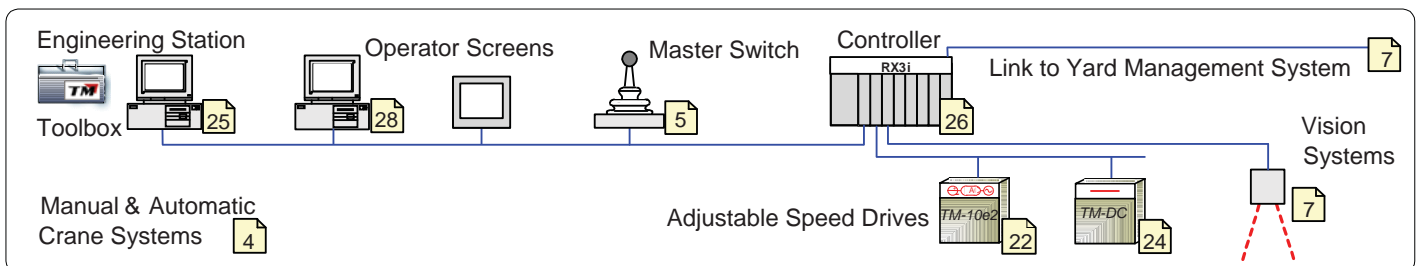

*Technologies Employed*

## Why Our Equipment Helps Set Production Records

The advanced features of the TMEIC Maxspeed® and the Maxview® visions system allow operation of the yard at a higher rate, often setting production records. In addition, the increased reliability helps reduce container and equipment damage. The main system features providing this superior performance are outlined below.

### System Features and Benefits

#### MAXview®

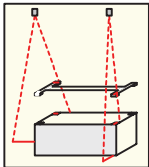

#### Maxview® Vision System allows Fast and Reliable Crane Operation

- Automatic landing system for accurate pick-up, drop-off, and stacking of containers
- Ship and Yard container profiling system provides safe and efficient operation of both manned and unmanned cranes
- Chassis Guidance System guides the truck driver into the exact target position
- Direct position measurements are unaffected by rope stretch and wheel slippage

#### MAXspeed®

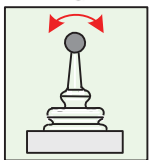

#### Maxspeed® Fast Operator Response Increases Throughput

- High-speed LANs (local area networks) link the I/O system, master controller, and drives so the container precisely follows the operator input in manual mode, and follows the system input in automatic mode
- Multi-tasking controller and the drives are all optimized for the fastest response



#### Remote Operator Console Streamlines Operation

- Automatic operation allows the operator to manage several cranes at the same time
- Remote operation facilitated with live video feed of container location and container corners
- Point and click container inventory interface allows the operator to locate containers and associated data in real-time
- Point and click generation of crane work instructions

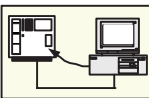

#### Ethernet Connectivity Increases Productivity

- Master controller, HMI system, and drives reside on industry standard Ethernet for rapid exchange of data with computer systems, and for fast configuration
- Standard software, including MS Open Data Base Connectivity (ODBC), XML, OLE for Process Control, plus drivers for MS SQL and Oracle, speed up communication between computer systems

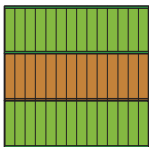

#### CraneDirector™ Container Tracking & Inventory System Provides Faster Operation

- All container movements are tracked and stored in a central data base accessible to yard management and all crane automation systems



#### Graphical, Real-Time Maintenance & Diagnostic Reporting

- System level equipment diagnostics makes crane status available in many locations
- Maintenance management planning system creates alarms when equipment maintenance is required

## Maxspeed Crane Systems

### Manual Crane Control Systems

The Maxspeed crane control system uses adjustable speed drives to control the speed and direction of the crane motors driving the gantry, trolley, boom, cable reels, and hoist. The speeds and directions are set by the operator using a master switch (joystick), which inputs signals to the controller through the I/O racks. A high-speed local area network (LAN) transmits the control signals to the individual drives, which generate the variable frequency three-phase AC power to the induction motors.

The link between the operator switch and the controller is optimized for speed so the operator has fast and responsive control of the motor.

Earlier crane systems used DC drives and motors, but most regions of the world are now standardized on AC technology. A typical manually-controlled system is shown below.

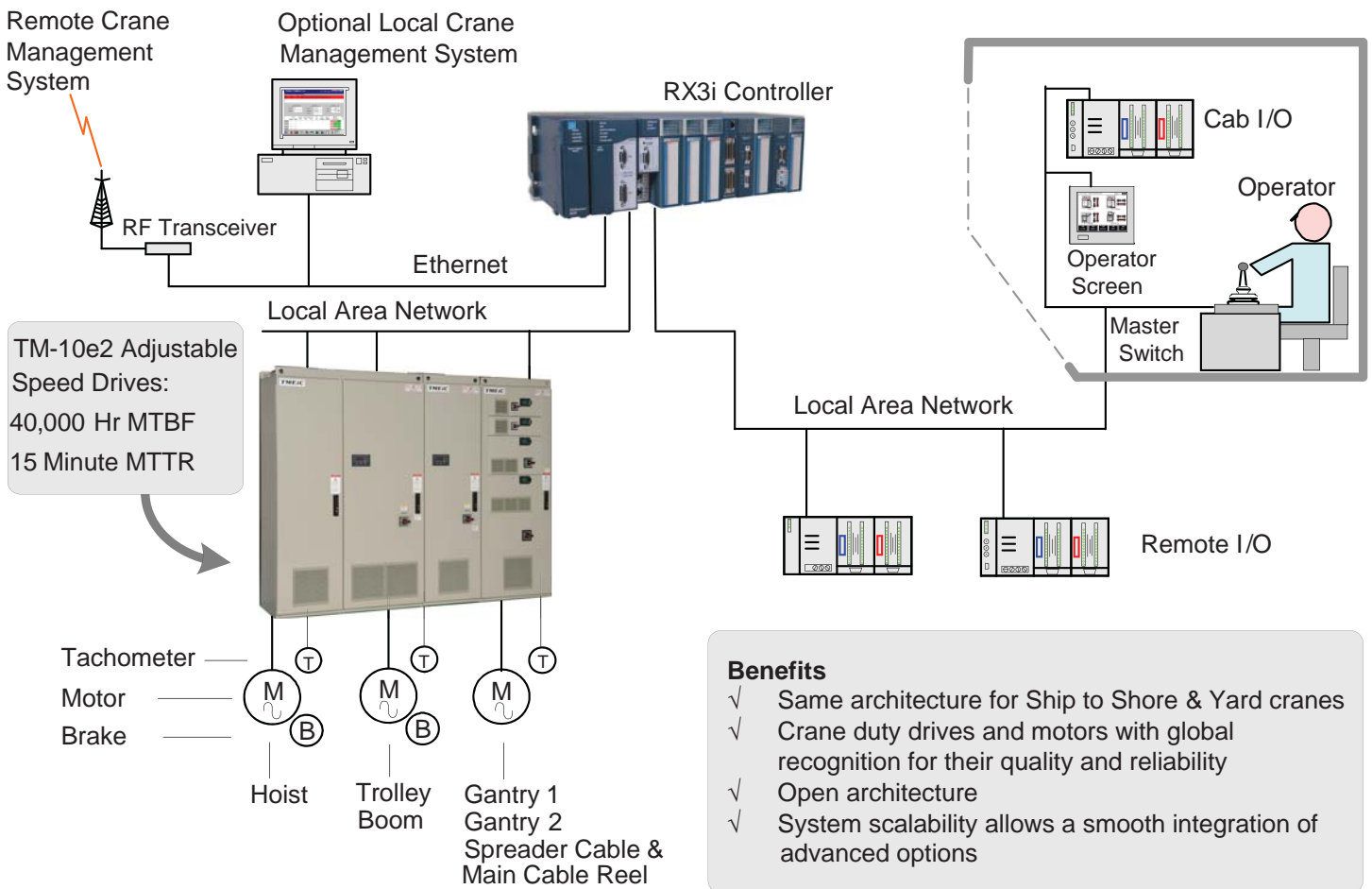

Maxview vision systems can be added to fully automate the crane so that, in the case of rail mounted gantry cranes for example, no operator is required. The system

is designed for computer control, but allows operator control from a remote location if a problem occurs. A typical computer-automated system is shown on page 7.

## Fast Response to Operator Inputs

Since the introduction of electronic controls, operator joystick response has been an issue because of communication delays. The time for an operator input to reach the motor depends on three factors:

- The data rate that is possible with the plant cable and communication components
- The efficiency of the protocol, driven by the size and quantity of messages required to transmit the packet of data
- The turnaround delay time in the sending and receiving devices

The Local Area Network (LAN) protocol has been specifically designed for the frequent transmission of small packets of data, in contrast to most popular protocols, which are optimized for occasional transmission of large packets of data. The crane control system is illustrated below showing the three high-speed communication links:

- A fast hard-wired link from the operator's master switch to the cab input/output modules
- A high-speed LAN between the cab input/output modules and the controller
- A high-speed LAN between the controller and the drive cabinet

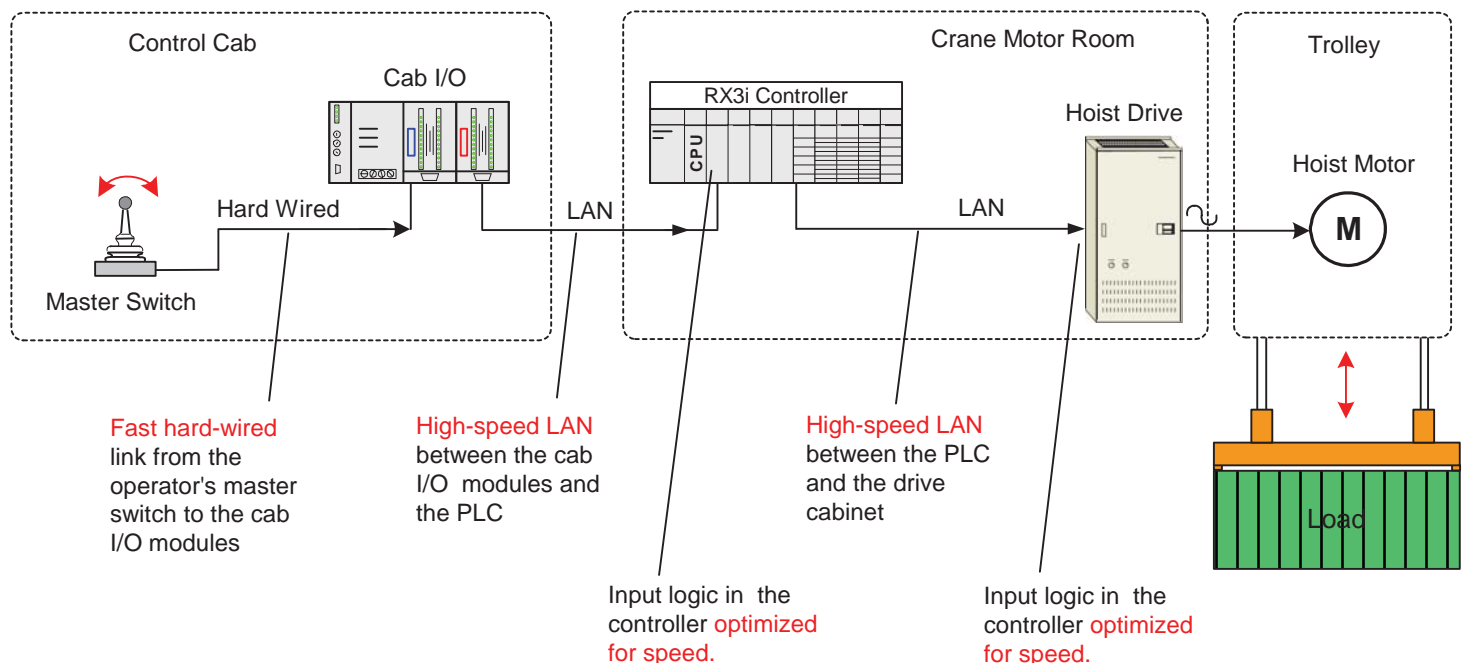

Immediate Operator Response using Fast Communications

### Optimized Communications

The RX3i controller has the latest technology with microsecond processing times. To provide the fastest possible response to operator inputs, the input logic in both the controller and the drives has been optimized. So, from the operator's perspective using the master switch, this technology provides responsive control with **hardwired-like functionality**.

### System Benefits

- The load precisely follows the operator input, even with the higher loads currently being used.
- The yard achieves a higher rate of productivity than previously possible, often setting production records.
- The use of single cable LANs means there are no expensive wiring requirements to link the various parts of the control system.
- All the drives are on the LAN, so all motors have the same instantaneous response to operator inputs.
- The response using the remote operator station is just as fast as using inputs from the cab.

## Energy-Saving RTG uses the MaxFuelSaver™ System



RTG energy saving tests



RTG operation in Yantai

### Save 30% diesel fuel using the MaxFuelSaver system

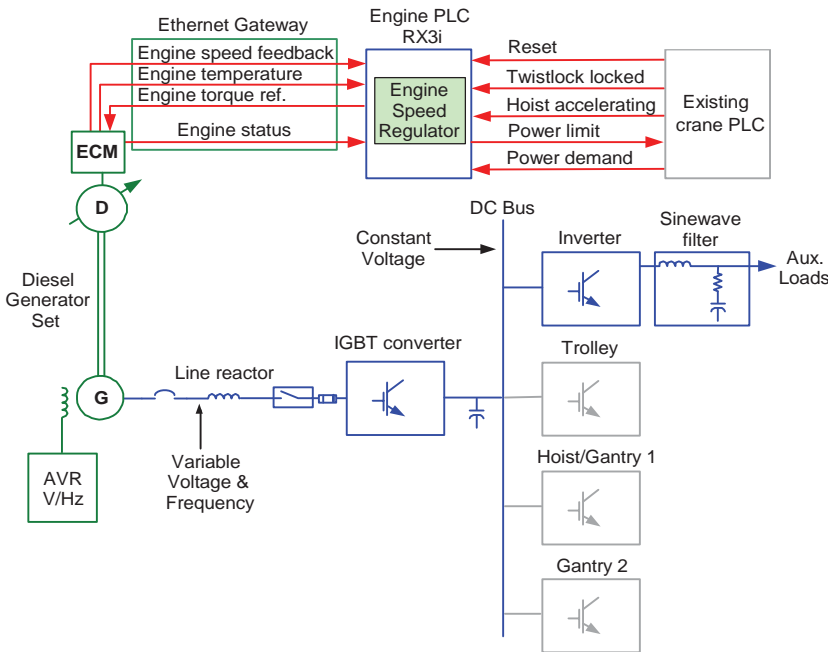

#### Characteristics:

- Standard TMdrive converter supplying DC bus
- Standard TMdrive-10 inverter supplying auxiliary loads
- Option to include a regenerated energy storage and recovery function to increase fuel savings
- Option for a stand alone unit to retrofit to third party inverters

#### Benefits:

- Reduced crane fuel consumption of 30% by optimizing engine speed and partially recovering regenerated energy
- Reduced engine emissions
- Reduced audible noise
- Reduced engine maintenance cost

### Energy Saving RTG Test Results

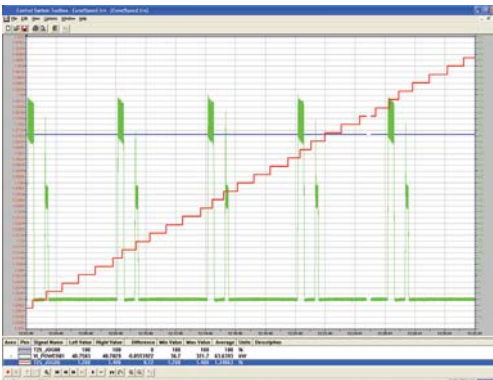

RTG before retrofit



RTG after retrofit with MaxFuelSaver

- Engine speed
- Fuel consumption (accumulated)
- Power demand

Several months of tests on both Tier 2 and Tier 3 diesel generators produced fuel savings up to 42% depending on the operating conditions.

## Maxspeed Sensorless Electronic Sway Control

This patented system reduces the sway of the spreader caused by motion in the trolley direction or gantry direction during load moves.

In **Manual** operation the operator is sending a speed reference to catch the load as it swings, see the dotted blue line in the time plot below. Manually catching the load is difficult and not all operators can do it successfully. The green line shows the swing motion of the load.

In **Automatic** operation with Sway Control, the system figures out how to catch the load by controlling the speed of the spreader, see the lower time plot. The operation is faster since the trolley and load come to rest at the same time, with no waiting for sway damping. The load is controlled in one swing of the pendulum, and does not overshoot the stop position.

Features of the TMEIC anti-sway control system:

- Faster moves and shorter cycle times
- Hardware sensors are not required so the initial and operating costs are lower, and the reliability higher
- The system is not weather-dependent, so snow and rain do not effect its operation
- Installation is fast since there are no sensors to calibrate
- Sway control can operate in manual as well as in automatic moves
- The trolley and gantry sway performance is  $\pm 50$  mm, which can be improved if required
- Skewing sway performance is less than one degree
- The system is less expensive and more reliable than hydraulic anti-sway control systems

The TMEIC sensor-less crane load measurements are covered by U.S. Patent 6,527,130.

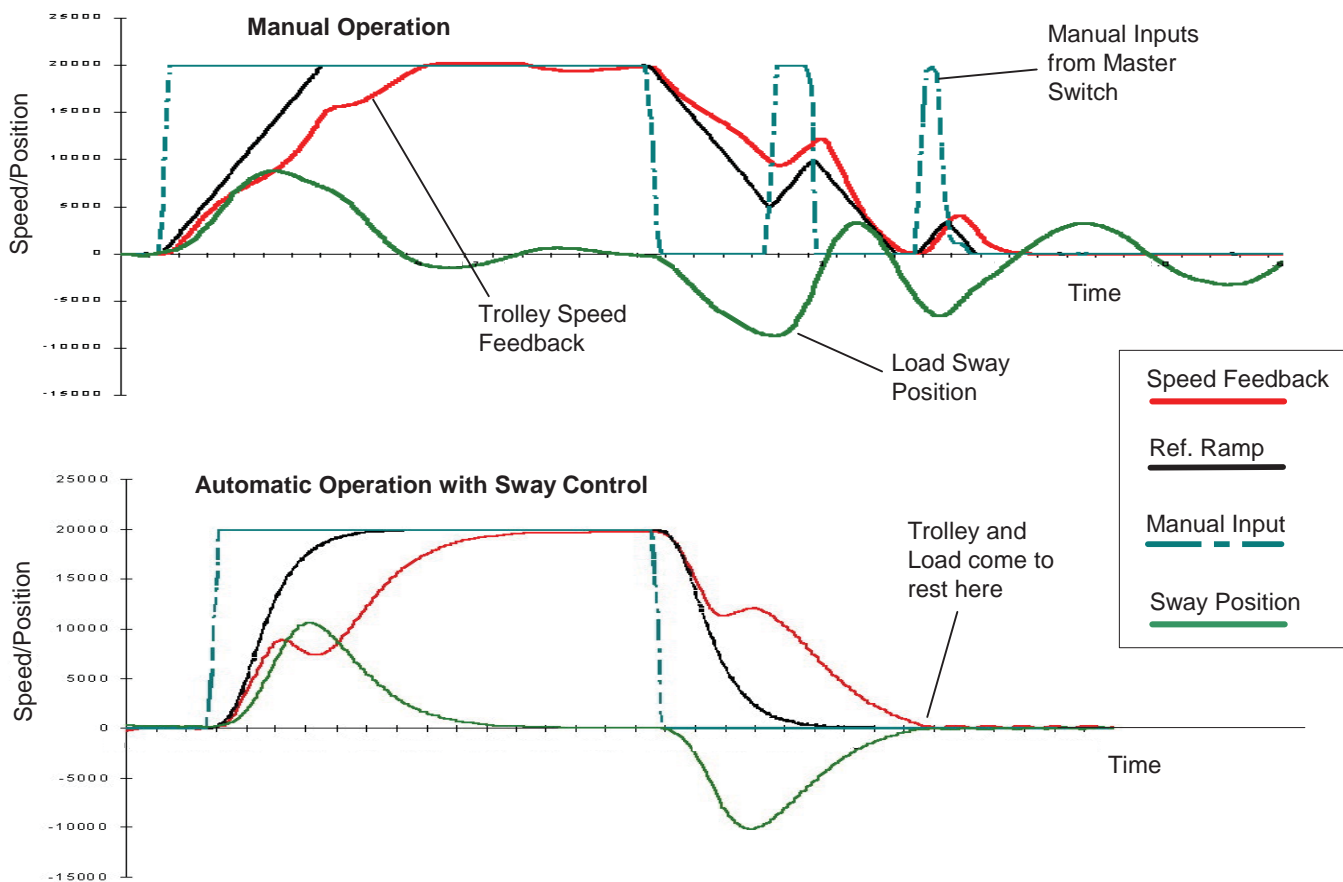

## Automated Crane System



The Maxview vision system, added to the basic Maxspeed control system and CraneDirector™ crane automation interface, provides several levels of scalable crane automation from semi-automatic with manual assistance up to fully-automatic, unmanned operation:

- Laser scanners detect the edges and ends of the container
- The controls position the trolley, chassis, and spreader
- Cameras read the container IDs and communicate with the yard director computer
- The gantry is positioned using transponders or satellite signals

### Terminal Operating System

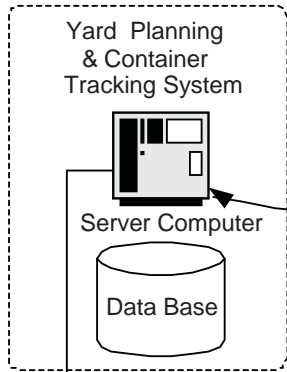

### Remote Operator Stations

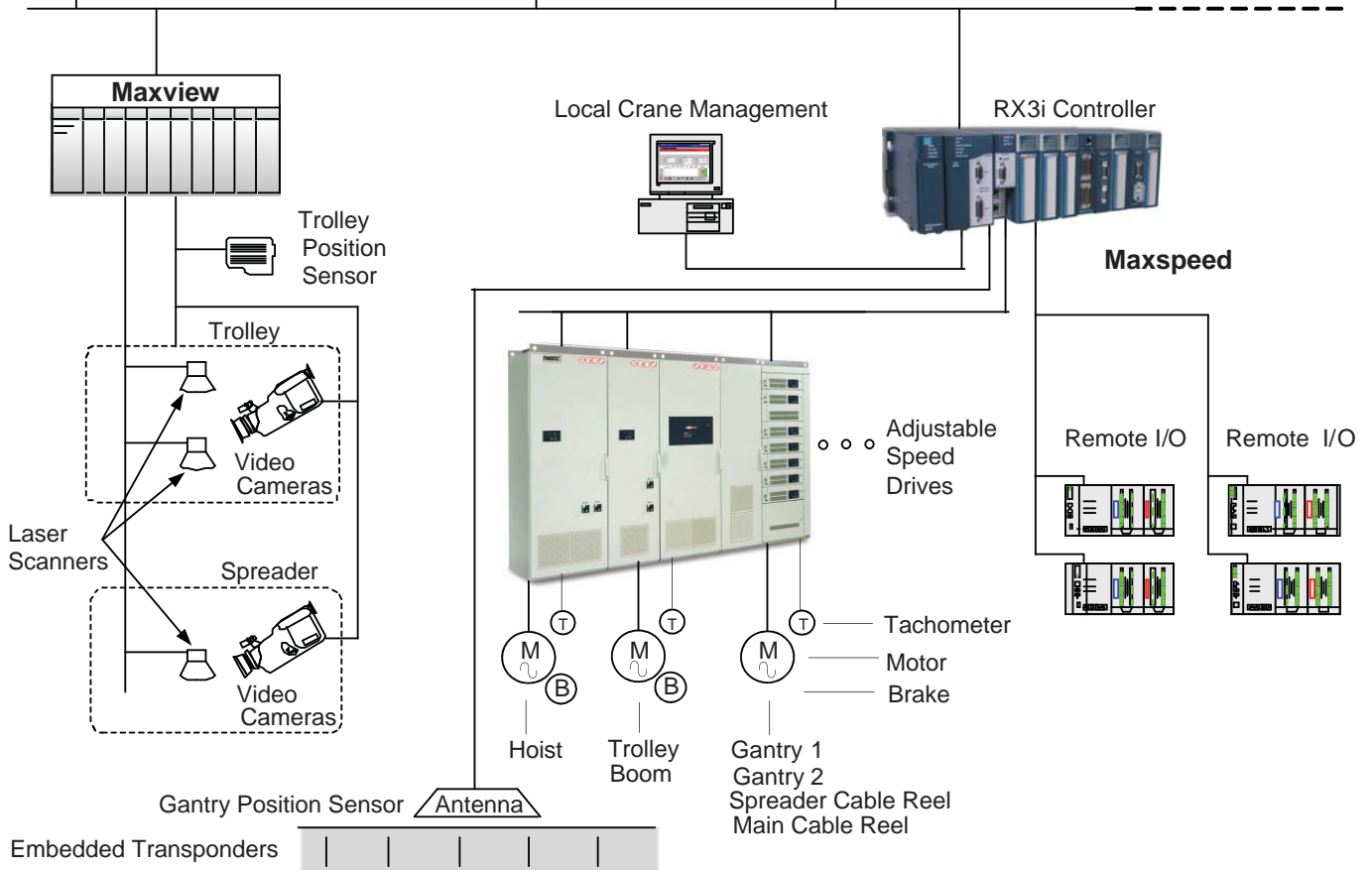
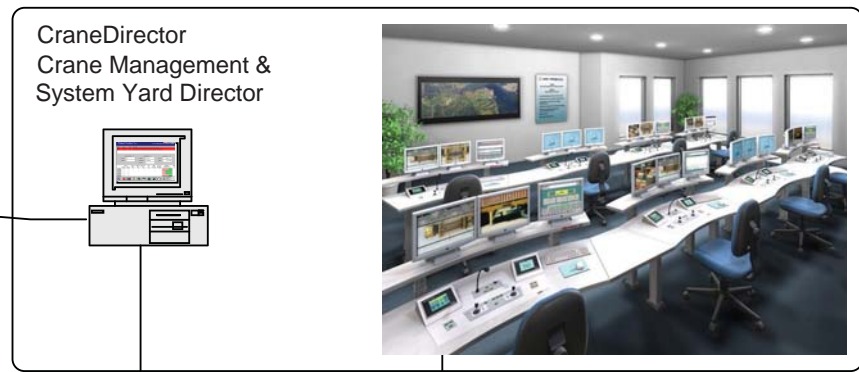



## Yard Data Flow & Control Functions

TMEIC supplies all of the crane control and automation equipment, operator interfaces, and software shown in the diagram below.

- The yard management system software in the central office is usually supplied by others
- The CraneDirector software linking the crane automation system with the yard management computer may be on the crane or in the central office
- The remote crane operator station may be on the crane or in the central office

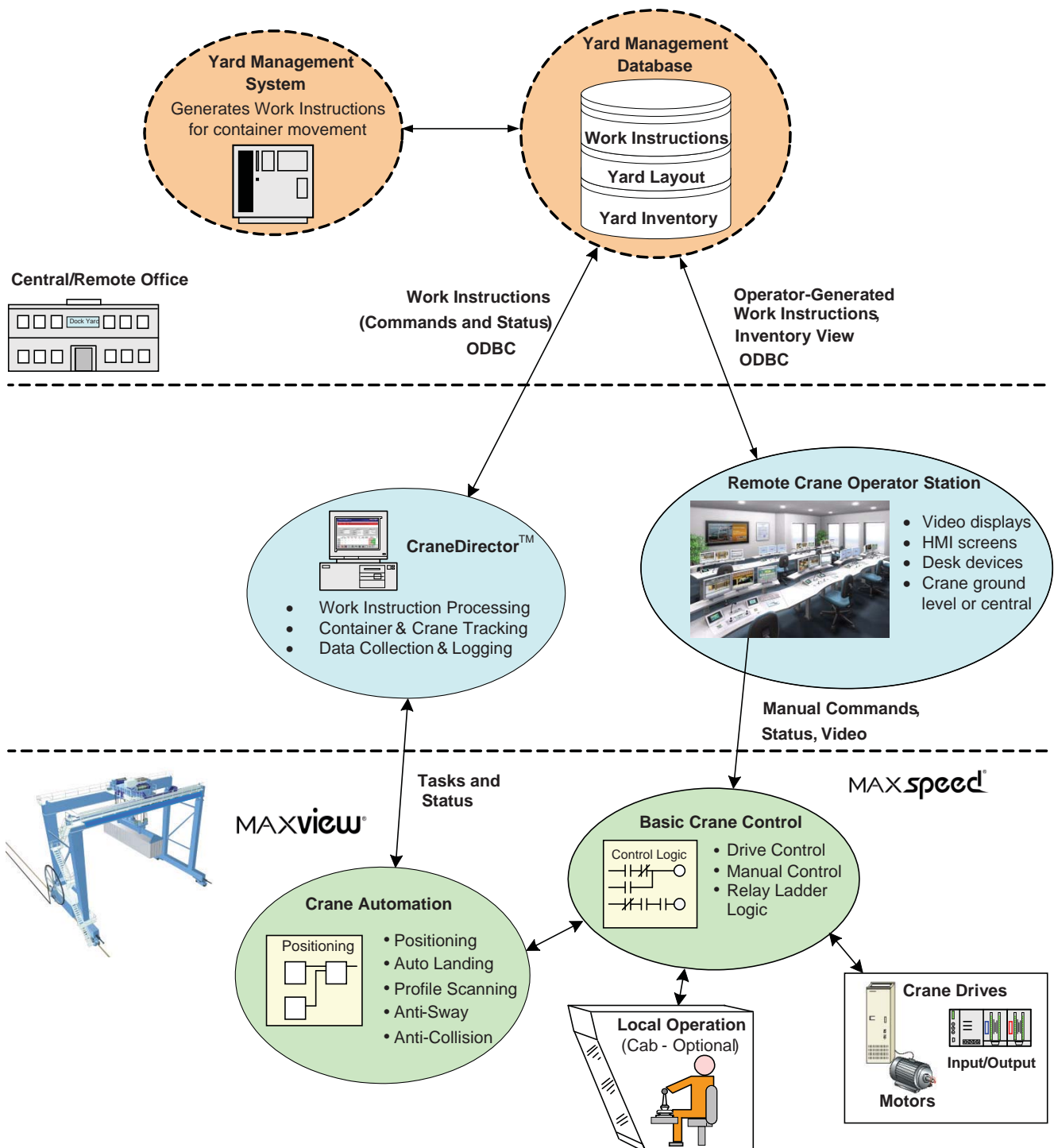

## Maxview® Systems

**Maxview** systems provide the measurements required for full automatic crane operation, as well as for increased productivity and reduced damage for manually operated machines.

### Maxview Automatic Landing™ System

This Maxview Automatic Landing system provides simultaneous measurement of the landing target and spreader during container pickup and drop-off so the load can be positioned directly over the landing target. This is essential for automatic pick-up and stacking of containers in the yard.

Laser scanners on the trolley measure the position of the spreader relative to the target container below (refer to the illustration on the right). Using these measurements, the Maxspeed® crane control automatically picks and lands containers in the yard, or places them onto trucks or automatic guided vehicles.

The stack profile option provides a profile of the containers in the yard for safe and efficient operation of both manned and unmanned cranes. The stack profile is used by the crane automation system to continuously calculate the safe height for automatic moves.

### Maxview Smart Move™ System

The Maxview Smart Move system is tailored for RTG and RMG cranes. It dynamically measures the spreader position and the objects below the crane, providing trolley slowdown and stop inputs to the crane control system to help prevent spreader collisions and stack topples.

### Maxview Clear Path® System

The Maxview Clear Path system provides collision and area protection for both dockside and yard cranes. The distance between the crane and obstacles in its motion path is continuously calculated; the Maxspeed crane control uses these measurements to assure operation at the optimum, yet safe, speed. Measurement data and sensor diagnostic information is readily available via Crane Management System (CMS) screens.

### Maxview Gate Monitor™ System

The Maxview Gate Monitor system provides a continuous view of the lanes at your truck gates, 24 hours per day, 7 days per week. This Maxview system analyzes this view and provides your systems with critical data about the traffic through your gates, including confirmation of empty chassis at the gate, detection of all combinations of loaded and empty chassis, and detection of any vehicle in a gate lane.

### Maxview Chassis Guidance™ System

The Maxview Chassis Guidance system cuts cycle times and increases productivity by guiding the truck driver into the exact target position under the container-handling crane for a quick container transfer.

### Custom Maxview Systems

We can design systems to meet your special measurement needs, on the cranes or elsewhere in the terminal.

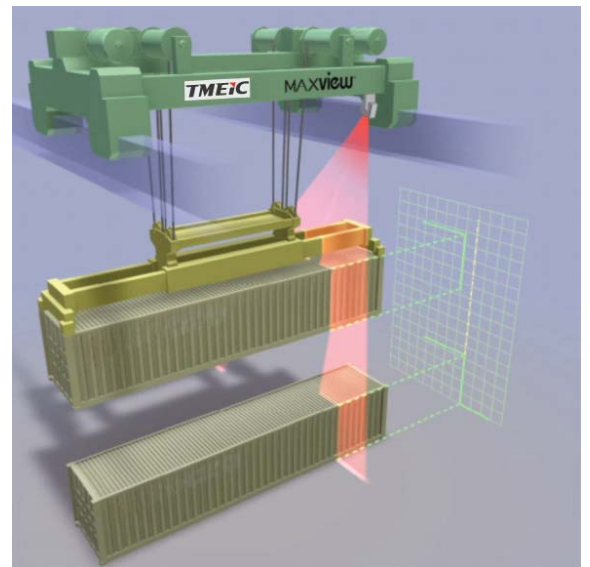
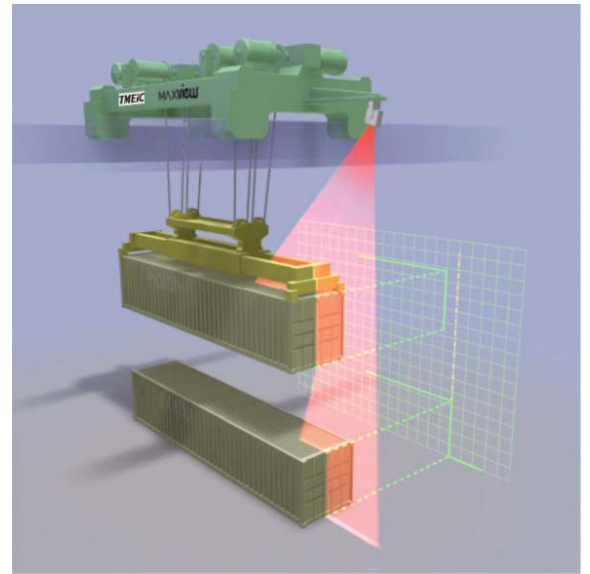

**Maxview** Sensors detect container ends and sides

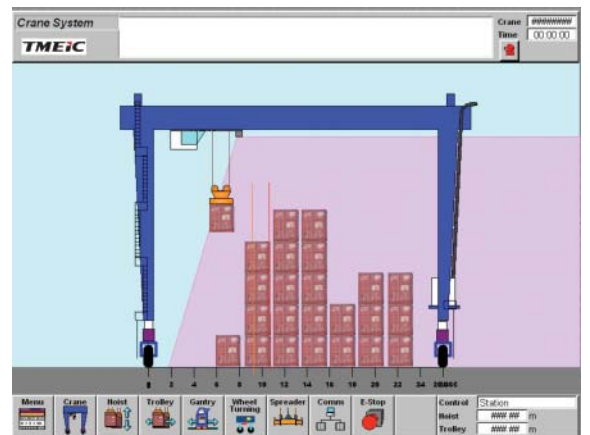

**Maxview** Smart Move system on an RTG Crane

## Maxview Smart Landing®

The **Maxview Smart Landing** system is a laser-based ship profile and operator landing assist system that increases ship-to-shore crane productivity and reduces damage and operating noise. The system is in service on ship-to-shore cranes today.

The design is based on TMEIC's extensive experience in crane automation applications in the container handling and other heavy material handling industries.

The system is particularly effective in assisting the operator during container pick-up and drop-off in deep vessel cells, resulting in increased productivity. Once in the cell, the operator can lower the spreader at "full stick", while the system reduces the speed as required for an optimal, soft landing at a predetermined speed.

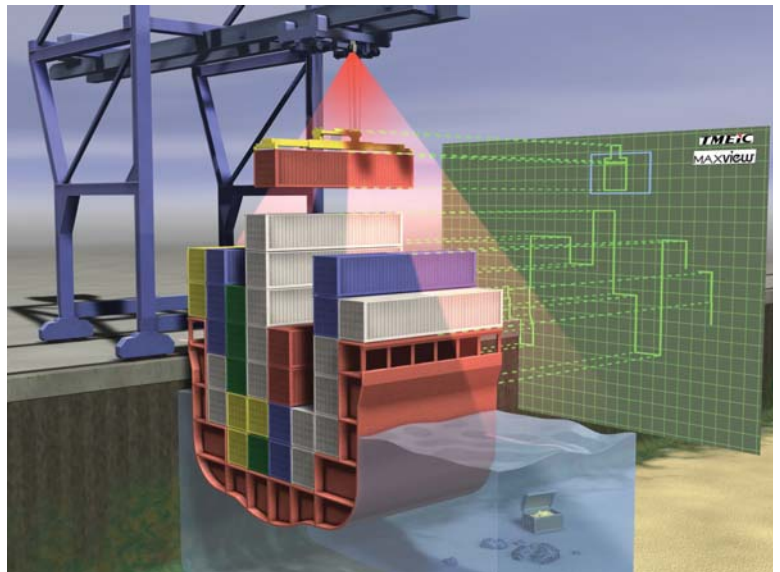

### Benefits

- **Reduced wear and tear on the spreader and head block** - the hoist speed is limited to a pre-set value as the spreader approaches the pick-up or drop-off point to assure smooth, soft landings.
- **Reduced wear and tear on crane structure and wire ropes** – smooth landings eliminate slack rope conditions and reduce crane structural oscillations.
- **Reduced container damage costs**
- **Hatch cover detection** can be used for operational tracking and to enforce limitations during handling.
- **Reduced operating noise level** due to softer landings on containers, and hatch cover handling
- **"Flipper Up" confirmation at vessel deck level** further reduces spreader damage.

### How it works

The **Maxview** system uses a laser scanner and TMEIC's **Maxview** software modules to measure and continuously update the profile of containers and other obstructions under the crane. The **Maxview** laser scanner has a range of over 80 meters, which provides measurement to the bottom of the deepest vessels. The profile is updated continuously, without need for additional trolley motion (including during the first move over the vessel). The **Maxview** system also tracks the spreader position (hoist position and sway), and continuously compares the distance between the spreader plus load and all objects in the stored profile. The system can be easily retrofitted onto existing cranes.

The **Maxview Smart Landing** Crane Management System (CMS) screen is provided for the crane operator to increase visual awareness of the profile of containers and objects below the crane. This CMS screen also indicates the system status.



Spreader in cell (view from cabin)

## Advanced Automation Systems

Sophisticated sensors are mounted on the crane to measure the position of the moving parts and the load so the crane can operate automatically. The various sensing systems are shown in the diagram below.

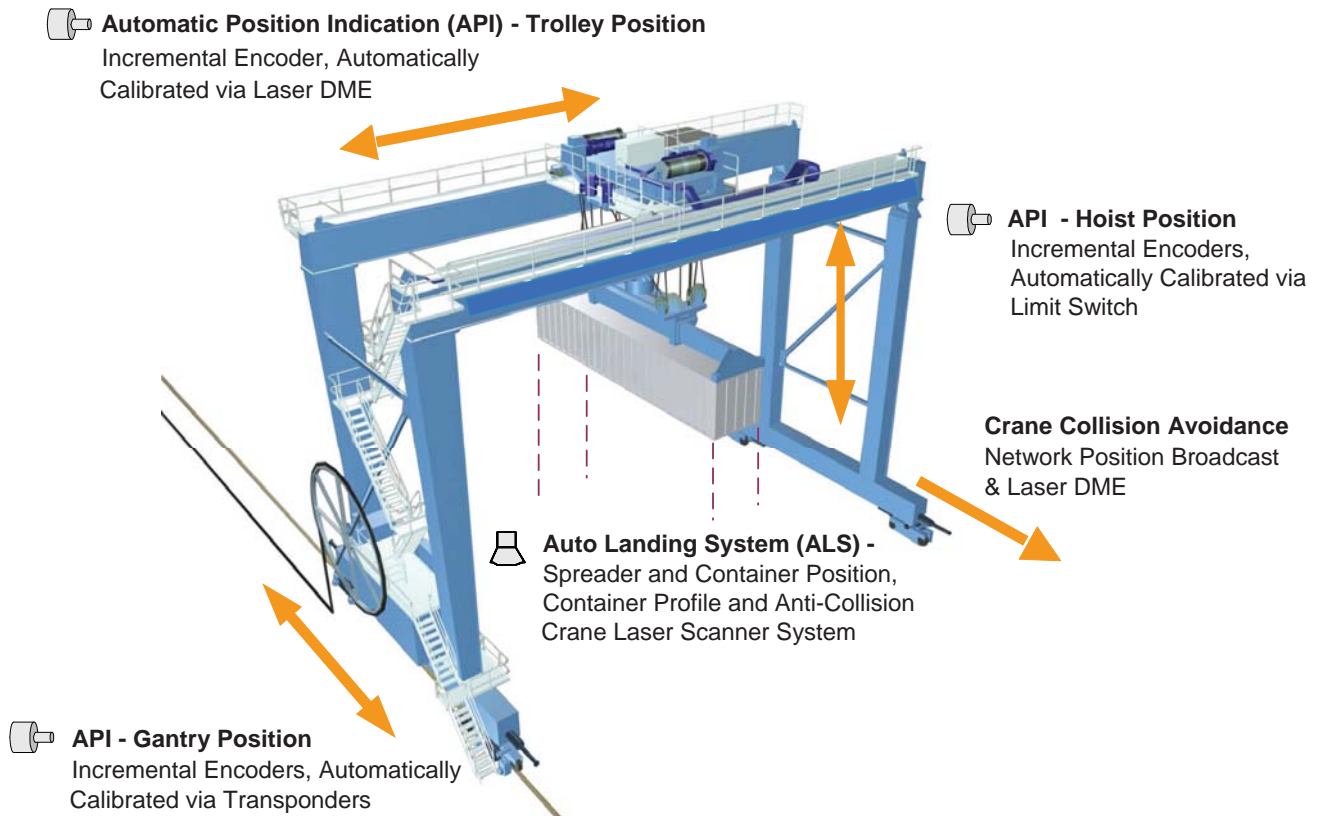

**Automatic Position Indication System (API)** – The API system makes direct measurements of the gantry, trolley, and hoist position via laser rangefinders, unaffected by factors such as rope stretch and wheel slippage.

**API - Gantry Position.** An antenna picks up the signal from a transponder embedded in the surface. An interpreter card generates a corresponding code signal, which is sent to the crane control so the gantry can be positioned accurately. Alternatively, signals from the GPS satellite system can be used for positioning.

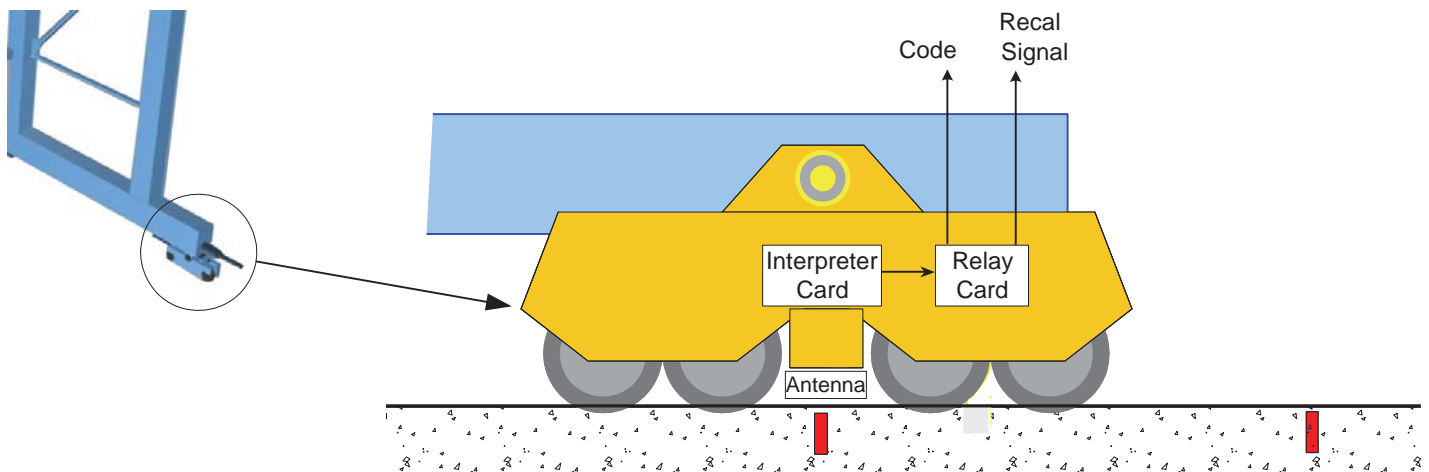

## Multiple Crane Automation – Yard Level System

Multiple cranes communicate with the yard management system over fiber optic cables. The cables come out of the crane through a cable reel into a trench, and are connected to an Ethernet fiber optic hub. As an option, wireless communication can be used instead of fiber optics. The network uses standard Internet Protocol (IP) for control and video signals, and the network "heartbeat" is monitored for safety and emergency stop functions.

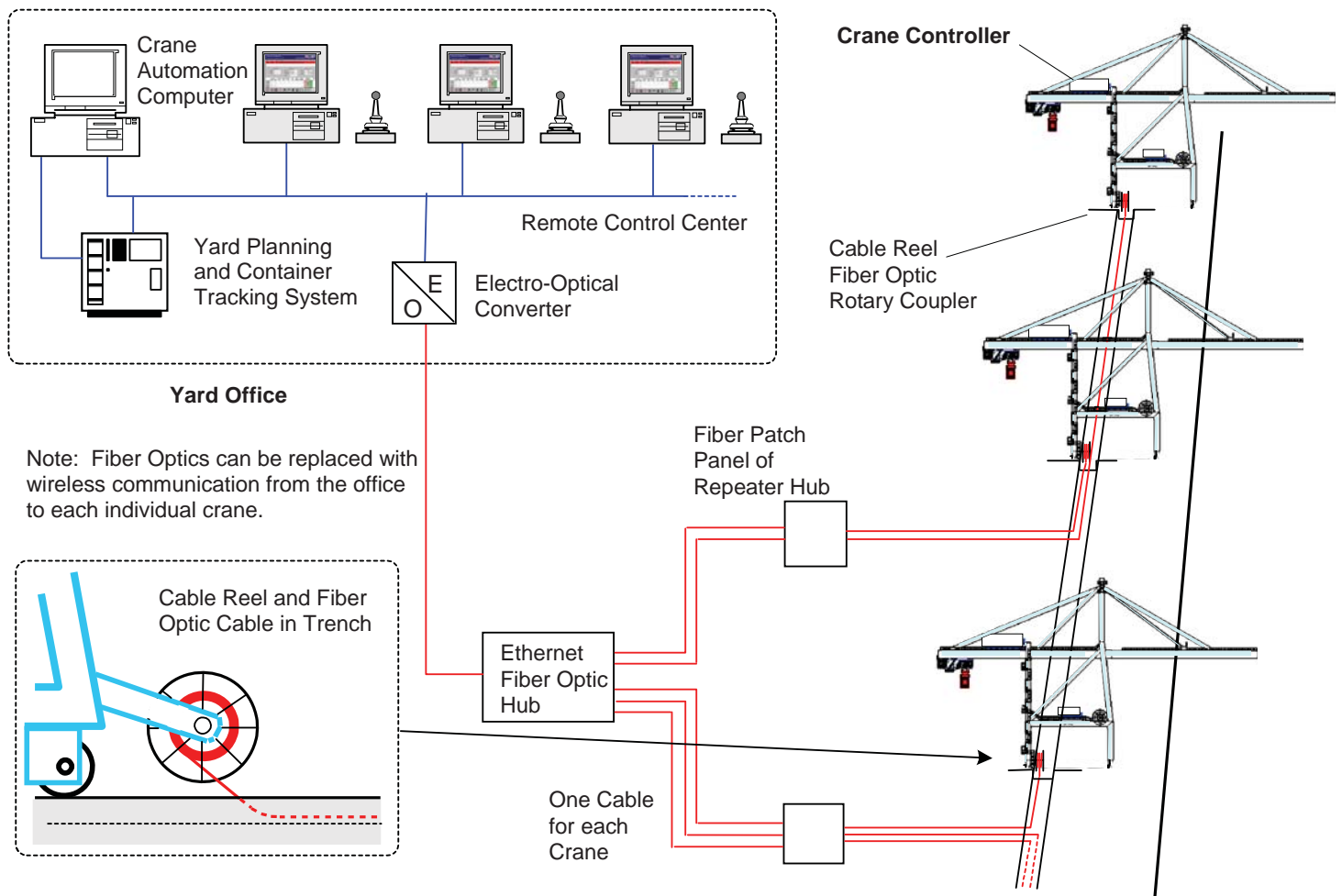

Note: Fiber Optics can be replaced with wireless communication from the office to each individual crane.

### Example of Yard Automation

TMEIC's experience includes the control and automation of overhead bridge cranes in slab and coil yards. TMEIC offers fully automated solutions for slab, ingot and coil handling, from automation of individual cranes to management of the entire yard. Some of the advantages:

- Labor savings
- Reduced equipment maintenance and down-time
- Improved product tracking
- More precise product placement and storage
- Increased safety during heavy material handling in the harsh environment of a metal rolling mill



## Project Engineering



### TMEIC's Crane Engineering Team in Virginia

#### **Dedicated Crane Engineering Team**

The material handling engineering team is dedicated to the crane control and automation business, and gained experience working in the ports with technicians and mechanical suppliers. This engineering background, coupled with state-of-the-art technology, enables TMEIC to consistently meet the demanding requirements of the industry.

Experienced crane engineers jointly define the equipment and control strategy with your engineers and the OEM. This is followed by detailed design of the operator stations, configuration of the drives, and master control programming.

#### **Exhaustive Factory System Test Minimizes Risk**

We understand that late delivery is very expensive, so we take several steps to hold our aggressive startup schedule:

- Complete factory system test includes simulation of each AC and DC drive and motor, allowing us to "move loads" from the yard operator's perspective.
- The local commissioning engineers are part of the project team, allowing a seamless transition from the factory to your yard.
- Factory automation engineers organize the factory test and assist with the commissioning.

#### **The Local Commissioning Team ensures you have Knowledgeable Ongoing Service**

TMEIC's Installation & Field Service organization is broad and deep with extensive experience in the industry, providing you with a strong local service presence for startup and ongoing service work, both in the U.S. and overseas.

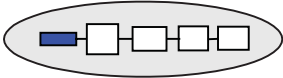

## Technical Proposal Specification

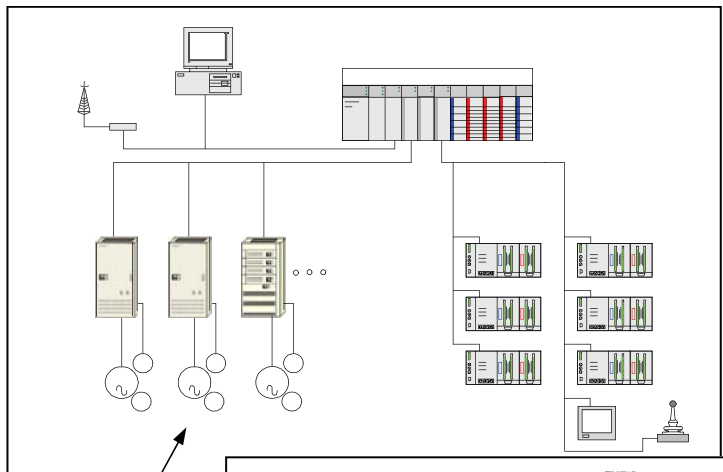

System architecture illustration

Thorough description of control functions

Detailed description of equipment

During your project planning stage, experienced material handling application engineers prepare a technical proposal that includes:

Customized system architecture for your project

- Detailed system equipment specifications
- Formal bid documentation



Our application engineers are highly qualified, and many of them have over 15 years of material handling industry experience.

TMEIC Proposal for Automation of RMG's

Item	Qty	Description						
8140	1/C	<b>Automatic Position Indication System (APIS)</b> APIS is an absolute position measurement for each major crane motion. Some system software, and all of the sensor hardware, is specified elsewhere in this proposal. <ul style="list-style-type: none"> <li>• Absolute Spreader Height (relative to trolley) – via Crane Scanner System</li> <li>• Absolute Trolley Position (relative to gantry) – via Laser Rangefinder</li> <li>• Absolute Gantry Position (relative to crane rail) –via Transponder system.</li> <li>• Spreader Sway and Skew (relative to trolley) – via Sway &amp; Skew sensor system.</li> </ul>						
8150	1/C	<b>Sway Position Feedback System (SPFS)</b> SPFS provides measurements of the spreader position relative to the trolley centerline, including measurements of: <ul style="list-style-type: none"> <li>• Spreader displacement from the trolley centerline in the axis of trolley motion (trolley direction sway).</li> <li>• Spreader displacement from the trolley centerline in the axis of gantry motion (gantry direction sway).</li> <li>• Spreader skew angle relative to the trolley centerline.</li> </ul>						
8170	1/C	<b>AS2000 Sway Control System – Trolley Direction</b> Reduces sway of the spreader due to motion in the trolley direction during						
8172		<b>Master Control</b> <table border="1"> <thead> <tr> <th>Item</th> <th>Qty</th> <th>Description</th> </tr> </thead> <tbody> <tr> <td>5000</td> <td>1/C</td> <td> <b>Master Control Case</b>                       The TMEIC Master Controller panel is mounted in the electrical control room. It includes the GE FANUC PLC and all associated I/O module for monitoring and controlling those I/O devices, which are located in the machinery house, on the trolley girders and on the gantry legs. Within the master controller resides the crane system application specific software for crane function control and monitoring. The master controller communicates with the drives via a high speed Local Area Network (LAN) and monitors all I/O via GENIUS LAN. A fiber optic module is supplied in this case to facilitate fiber optic transmission of the GENIUS LAN data. All drives can be monitored simultaneously.                 </td> </tr> </tbody> </table> <p><b>NOTE:</b> [For the optimization of space usage within the E-House, the Master Control Case (MCC, Item 5000) will be combined with the ISP case (Item 7000) in one (1) enclosure.]</p>	Item	Qty	Description	5000	1/C	<b>Master Control Case</b>  The TMEIC Master Controller panel is mounted in the electrical control room. It includes the GE FANUC PLC and all associated I/O module for monitoring and controlling those I/O devices, which are located in the machinery house, on the trolley girders and on the gantry legs. Within the master controller resides the crane system application specific software for crane function control and monitoring. The master controller communicates with the drives via a high speed Local Area Network (LAN) and monitors all I/O via GENIUS LAN. A fiber optic module is supplied in this case to facilitate fiber optic transmission of the GENIUS LAN data. All drives can be monitored simultaneously.
Item	Qty	Description						
5000	1/C	<b>Master Control Case</b>  The TMEIC Master Controller panel is mounted in the electrical control room. It includes the GE FANUC PLC and all associated I/O module for monitoring and controlling those I/O devices, which are located in the machinery house, on the trolley girders and on the gantry legs. Within the master controller resides the crane system application specific software for crane function control and monitoring. The master controller communicates with the drives via a high speed Local Area Network (LAN) and monitors all I/O via GENIUS LAN. A fiber optic module is supplied in this case to facilitate fiber optic transmission of the GENIUS LAN data. All drives can be monitored simultaneously.						

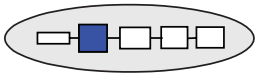

**Electrical and mechanical prints**

**Control logic design**

**Operator interface screen design**

The operator interface screen design includes a 'Spreader Status' section with a table of indicators:

Spreader Status		Solenoid Status	
Spreader Pump Running		Spreader Center Twistlocks Up Solenoid	
Spreader not Landed		Spreader Center Twistlocks Down Solenoid	
Spreader Twistlocks Unlocked		Spreader Twistlock Lock Solenoid	
Spreader Telescopic Permissive		Spreader Twistlock Unlock Solenoid	
Spreader Center TL House Down		Spreader 20 Foot Position Solenoid	
Spreader Normal Mode		Spreader 40 Foot Position Solenoid	

Based on the proposal specification, the project engineering team proceeds with four main tasks:

- Control Software Design.**  
 Control engineers configure the master controller logic, sequencing, and drives. The illustration above shows a typical logic function in Relay Ladder Diagram format.
- Operator Screen Design.**  
 Operator interface screens for operation and maintenance of the crane are configured using the HMI engineering tools providing real-time crane data and operator interaction.
- Hardware Design.**  
 All equipment is specified per the project requirements, and a complete set of elementary diagrams, layout, and outline drawings is created.
- Component Procurement.**  
 We work with our group companies to source the most cost effective system components for your application.



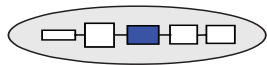

## System Test

TMEIC understands the importance of a thorough system test. Our engineering team conducts an exhaustive factory test in the large, fully-equipped system test lab featuring::

- Complete staging of the system with the controller, HMI system, networks, and all drive controllers.
- Unique to the industry, a motor and load simulator in the drive controller (see below) allowing lifelike simulation of the machine.
- Validation of all network interfaces, including drives, HMI stations, and other networked devices.
- Crane mechanical model in the PLC simulating the real world actuators and sensors.



The picture above shows one of our test labs, featuring;

- 200-plus drive controllers with simulators
- 64 HMI and touch-screen operator stations
- 10 RX3i PLCs
- Complete Maxview sensor systems

### Typical Factory Test Setup in the Test Lab

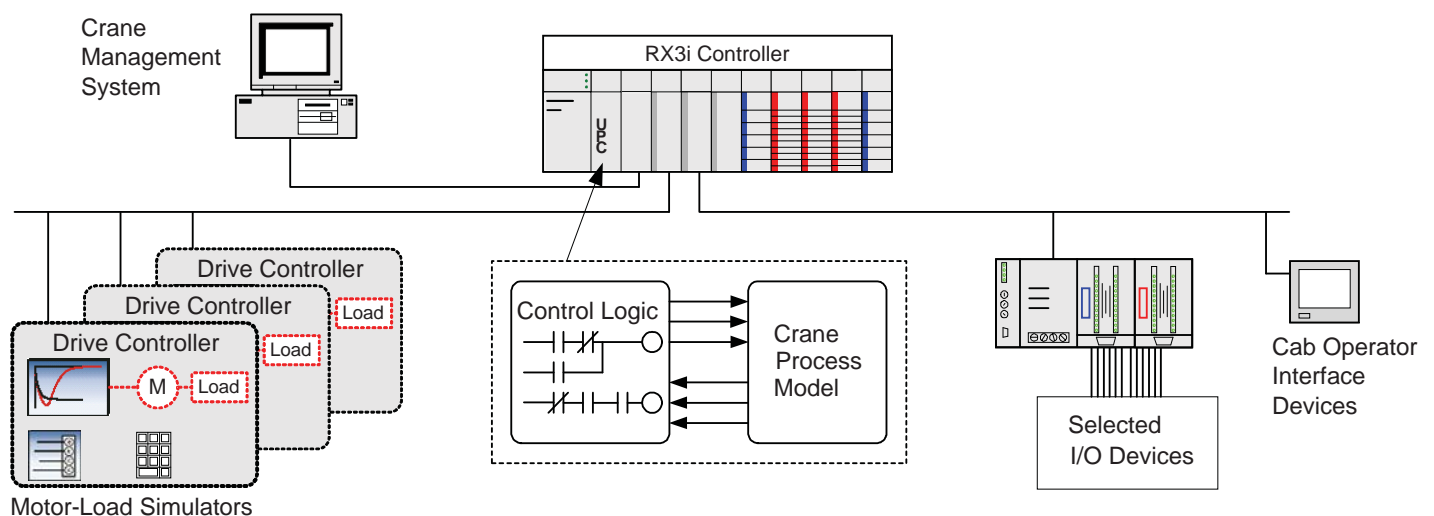

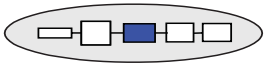

### Enabling Technology for Process Simulation in a Factory System Test



#### Real-World Crane Environment



#### System Simulation

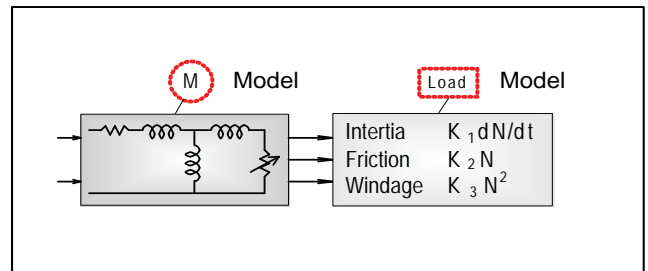
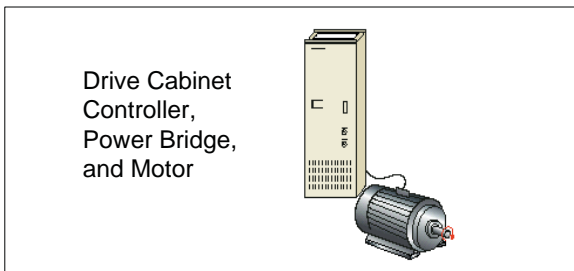
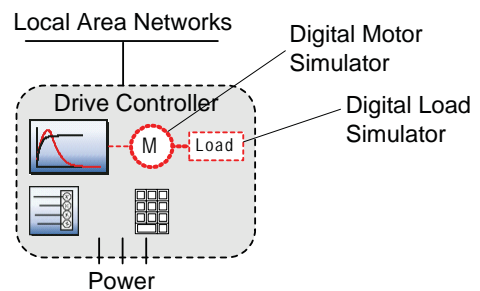
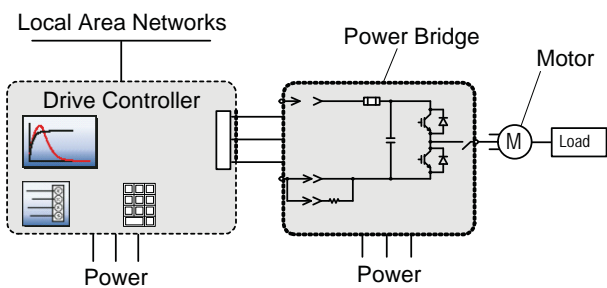

#### On the crane, AC and DC drives control motor speed and mechanical load

Each AC drive has a controller with I/O and a gate driver, which controls the power IGBTs in the power bridge. The power bridge generates the adjustable frequency AC voltage supply to the three-phase motor controlling its speed and torque.

In the case of a DC drive, the power thyristor-based power bridge converts the AC power to a variable DC voltage, which is applied to the motor armature. This controls the DC motor's speed and torque.

#### In the System Test, the drives control a motor and mechanical simulator

Each AC/DC drive in the system has its own digital motor simulator based on a dynamic mathematical model. All drive simulators are networked with the master controller and operator stations to test the entire system in real time. Starts, stops, running modes, response to manual inputs, LAN continuity, and drive configuration are all validated.

This unique capability allows the entire team to obtain an intimate understanding of the system prior to the commissioning, ensuring a smooth, on-time startup for your project.



## System Commissioning

In the commissioning phase of the project, the TMEIC team includes the field engineers you know and trust, along with the engineer who designed and tested the system. This overlap of teams between the factory and the crane site ensures a smooth and on-schedule startup.

The TMEIC service engineer, who is responsible for startup and commissioning, and for any future service required at the port, is part of the project team and participates in the design to become familiar with the system. The available support for commissioning includes:

- Local service team
- Factory service engineers
- Factory control engineers

The commissioning phases are shown below.

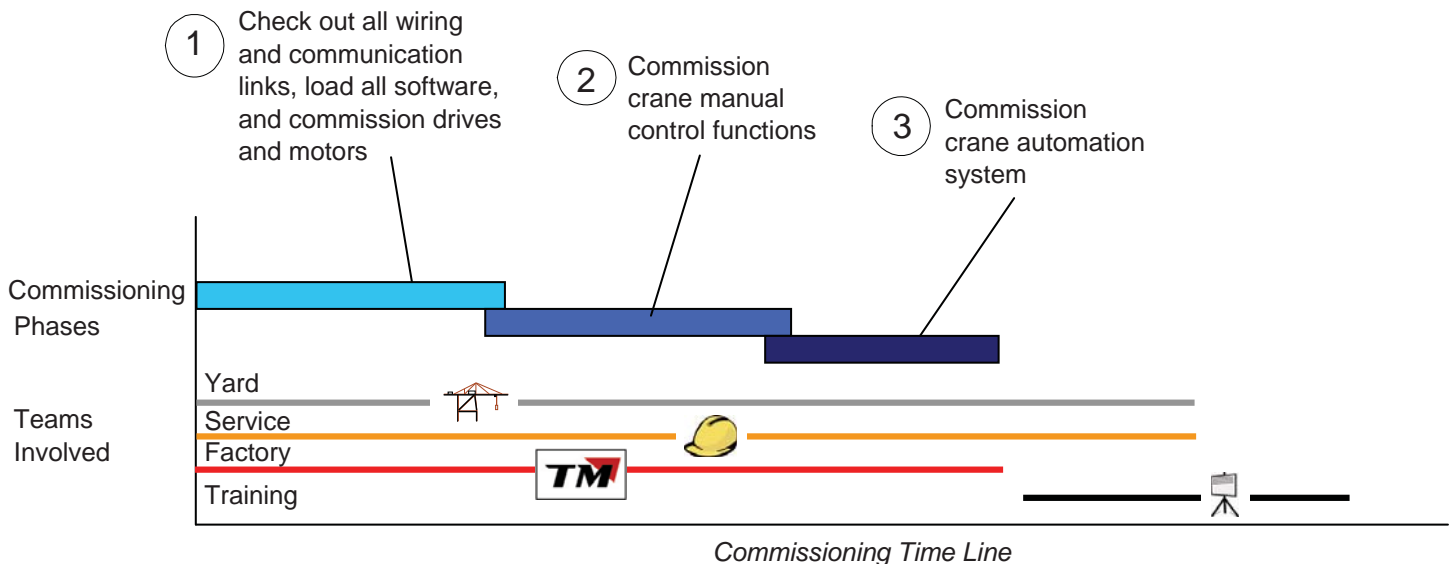

Working with the Field Service team, TMEIC offers a single source for installation and commissioning. All three phases above are compressed by:

- The exhaustive factory acceptance test that includes all drive controllers, master controller, and communication links
- The timesaving commissioning and drive tune-up Wizards
- Training and familiarization of the entire team with the system at the factory

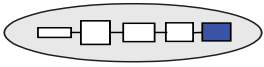

### Global Customer Support Network

Comprehensive technical service is provided by our Customer Support Organization, staffed by TMEiC service engineers with offices and spare parts depots across the globe.

#### In North and South America

Customers are supported by the TMEiC Corporation service personnel, design engineers and Spare Parts Depot in Virginia, and the TMEiC Factory in Japan.

#### In Europe

TMEiC service engineers service all drive systems in Europe, supported by the European TMEiC Spare Parts Depot.

#### In Asia and the Pacific Rim

TMEiC services drive systems throughout China, India and the Pacific Rim, supported by multiple Field Engineers, Spare Parts Depots, and the TMEiC factory in Japan.

#### Remote Drive Diagnostics

TMEiC supports drive customers through the **Remote Connectivity Module (RCM)**, a remote diagnostic service link with the TMEiC design and service engineers in Roanoke, Virginia. The RCM enables seamless integration between your drives and our engineers.

#### Remote System Diagnostics

TMEiC's remote system diagnostics tool, included in level 1 software, offers a quick path to problem resolution. System faults are automatically identified, and provide an integrated view of product, process and system information. TMEiC design and service engineers in Roanoke, Virginia, can analyze the data and provide steps for resolution.



For Service or Parts, call

1-877-280-1835

INTERNATIONAL:

+1-540-283-2010

24 Hours / 7 days

#### Remote Diagnostic Service reduces Mean Time To Repair (MTTR)

Remote diagnostic service offers protection for your investment, by reducing downtime, lowering repair costs and providing peace of mind. Remote diagnostics requires an internet connection between your plant and TMEiC for retrieval of fault logs and files to diagnose drive or system issues.

#### Features

- Reduced downtime and Mean-Time-to-Repair
- Secured connection
- Fault Upload Utility

#### Benefits

##### Quick support saves thousands of \$ in lost production

TMEiC engineers can quickly connect to the drive and diagnose many issues in a matter of minutes.

##### Customer-controlled access

All remote activity is conducted with permission of the customer. Drive start/stop is not permitted remotely.

##### Proprietary Fault Upload Software

Historical drive faults are identified; TMEiC design and service engineers can analyze the issue resulting in the fault and provide a solution.

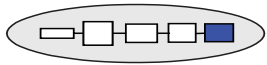

## System Maintenance & Service

### Training at the Factory or in Your Facility



Customer engineers, maintenance, and operations personnel are trained on the drives and control system at the TMEIC Training Center in Virginia. This world-class facility has large classrooms and fully equipped training labs.

Classroom and hands-on training consists of 50% class time and 50% hands-on lab time. Topics include:

- Overview of the drive system
- Function of the main assemblies
- Technical details of the components
- Operation of the control system from the local touch panels and the central HMI
- Drive and control system tools,
- System diagnostics and service

### Customized Training at the Port

As an alternative to the standard factory training in Virginia, TMEIC can offer a course tailored to your project and held at your location. In this case, a project engineer and local service engineer train your operators, maintenance technicians, and engineers in your facility.

### Complete and Detailed Drive System Documentation

Along with the hardware and software, TMEIC delivers complete system documentation:

- An electronic instruction book with all the prints on CD with a hyperlink index
- System configuration on CD and a hard-copy form
- Detailed system manual
- Recommended wiring and grounding procedures
- Renewal parts list
- Standard third-party vendor documentation

At the end of the project, the drawings are updated to reflect the final changes. Final drawings are delivered to the customer on CD ROM in AutoCAD format, together with a hard-copy version.



## TMEIC's Family of AC/DC System Drives



TMDrive-10e2



TMDrive-DC



TMDrive-30



TMDriveMVG

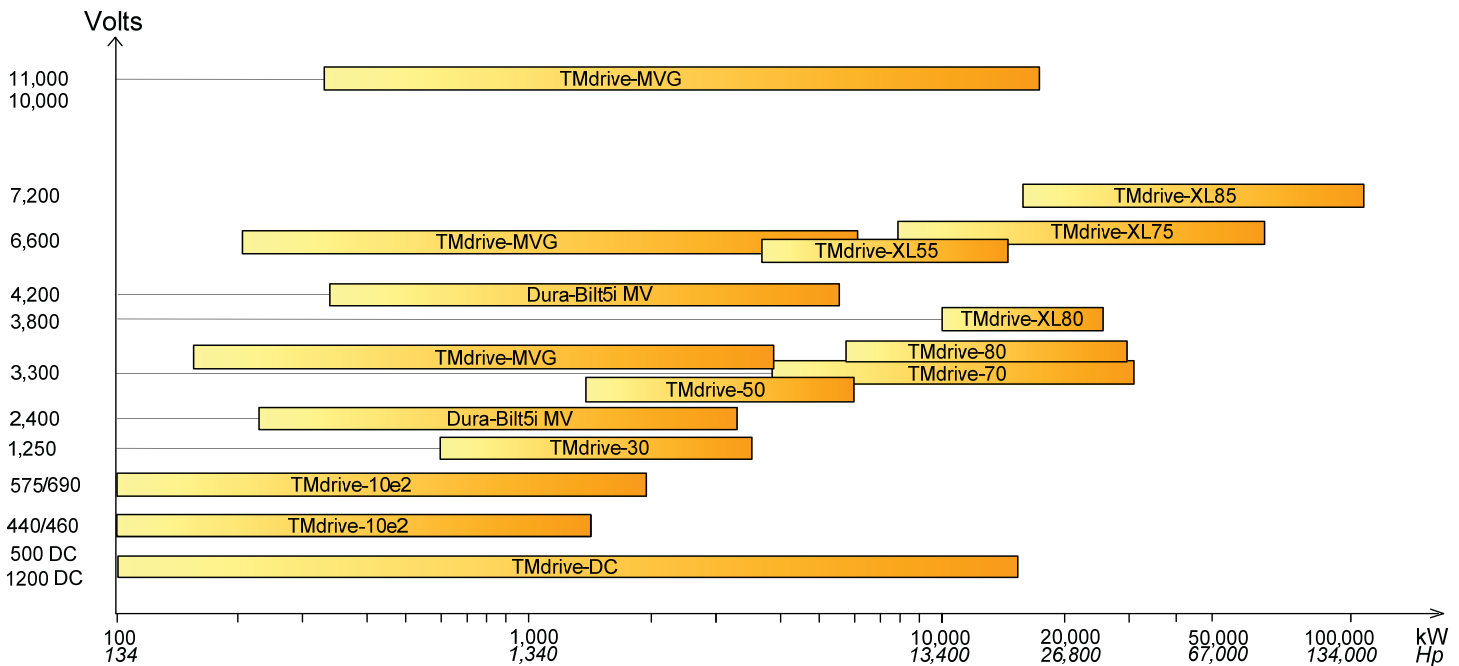

### Features of the Drive Family

#### Common Control Hardware

All TMDrive products share a common architecture:

- Common I/O boards
- Common LAN interface boards
- Common front panel display and keypad options

#### TMDrive-Navigator, for all TMEIC drives

The TMDrive-Navigator, a Windows-based software tool, is used to configure and monitor all TMEIC system drives. The TMDrive-Navigator features:

- Integrated trending
- Animated function block diagrams
- Commissioning and tune-up wizards

#### Legacy System Interfaces

It is important for new drive system equipment to integrate with legacy systems. All TMEIC system drives have several features that address this point:

- ISBus, Modbus, Profibus-DP, and DeviceNet LAN interface boards for PLC-based systems
- Common Toolbox configuration

### Benefits

Spare parts inventory is always an issue in crane automation. TMEIC reduces this investment with a common set of control hardware for all of your low voltage AC and DC system drives.

When commissioning the system, maintaining schedule is everything. The commissioning and tune-up wizards ensure that the system drives are not the critical path item in the start-up. In ongoing maintenance work, the integrated trending tools provide an in-depth view into the regulation functions.

The majority of crane automation projects today involve some form of modernization. The close tie that today's TMEIC system drives have with legacy systems reduces the cost of engineering, commissioning, and training.

## TMdrive®-10e2 Low Voltage System Drive



### Draw-Out Style Inverters

For applications up to 193 kW (249 hp), draw-out style inverters are available in a very compact package.

Draw-out inverters are mounted on heavy-duty slides with staggered dc bus connectors on the back that connect with the bus when slid into the cabinet.

Motor cables are terminated at a common terminal block in the bottom of the cabinet.

### TMdrive®-10e2

The family of low voltage AC system drives has an integral DC bus structure with a wide variety of inverters (DC to AC) and converters (AC to DC) to match virtually any application in the material handling industry.

- 400, 460, 575, or 690 volt operation
- Motor power up to 1,949 kW
- Regenerative converter option

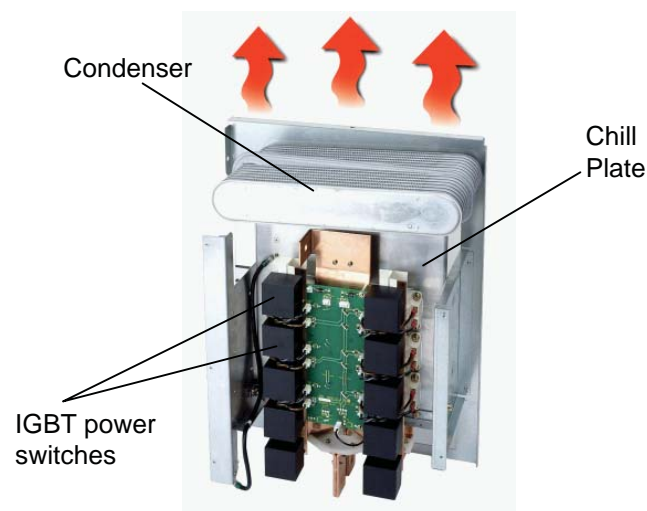

### Heat Pipe Cooling Technology

The use of heat pipe technology provides a dramatic advance in power bridge cooling, including a significant reduction in the footprint of the power bridge, and fewer fans lower the audible noise.

#### The Thermal Cycle

- 1 Condensate to Vapor**  
IGBT's are mounted to the multi-channelled chill plate which cools them. Heat generated by the IGBTs vaporizes the refrigerant, moving it upwards through the chill plate to the finned condensing unit.
- 2 Vapor To Condensate**  
Cooling air is pulled up through the IGBTs and the condensing unit, and cools the refrigerant, which condenses back to liquid.
- 3 Return of Condensate**  
The condensed refrigerant returns to the bottom of the chill plate to start the thermal cycle over again.

## TMdrive®-DC System Drive Overview



The TMdrive-DC family of system drives shares numerous components with the TMdrive-10e2 AC products and are composed of several frames offered in any combination of four form factors (digital front end (DFE) control retrofits, frame assemblies, module assemblies, complete cabinet assemblies).

This flexibility of form factors and commonality with the TMdrive-10e2 AC products suits the current modernization project trends in crane automation:

- Digital Front End (DFE) control retrofits on larger DC drives, saving the expense of replacing the existing power bridge and motor.
- Selected DC drive frame upgrades to address incremental power requirements.
- Frequent use of both DC and AC drive technology in projects.

### Featuring Flexible Mechanical Design

TMdrive-DC's flexibility in packaging allows it to meet virtually any new or retrofit application. Three of the more common applications are illustrated below, from a DFE module to a complete DC drive and cabinet.

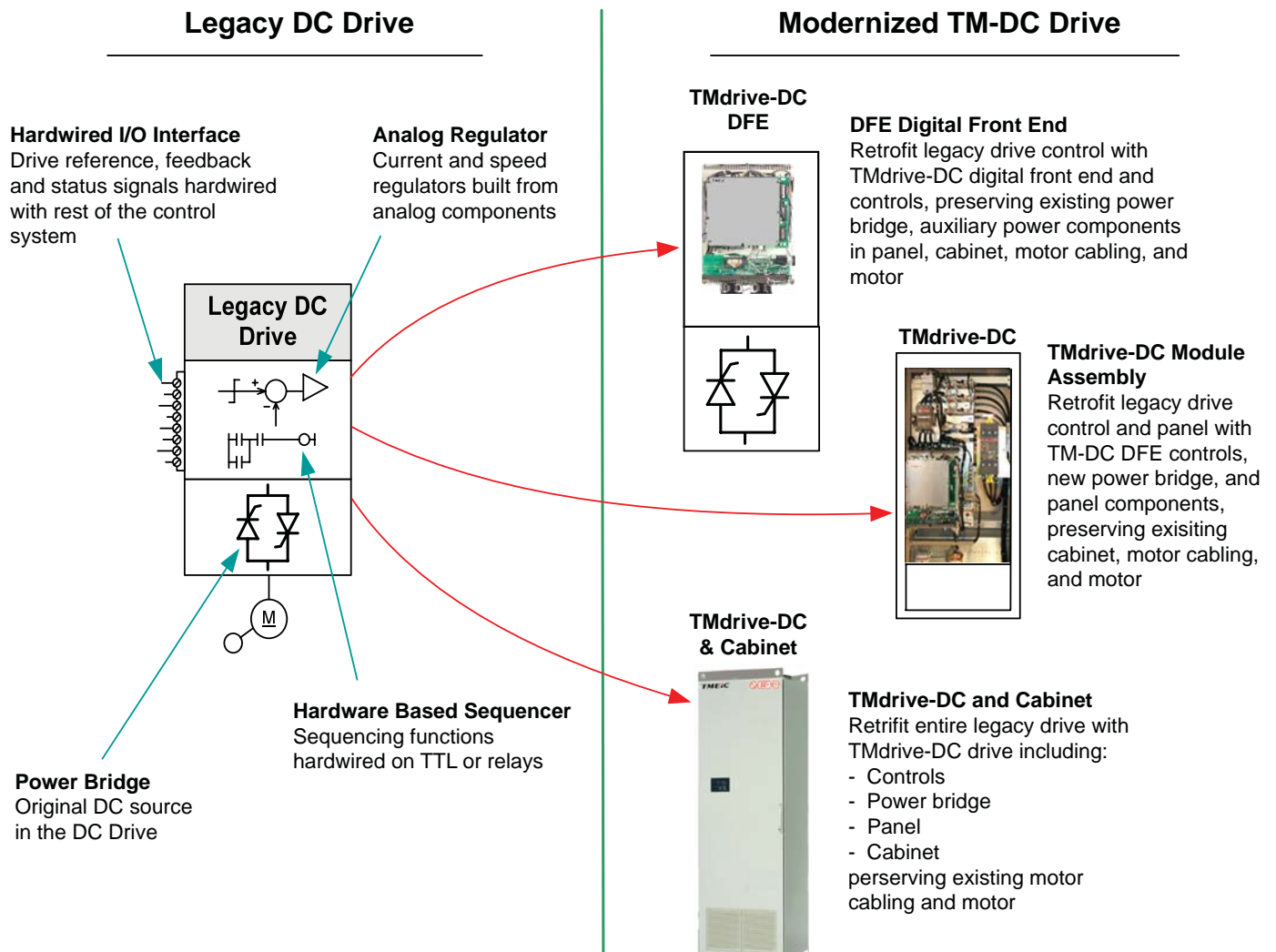



## TMdrive-Navigator Supports the Entire TMdrive Family

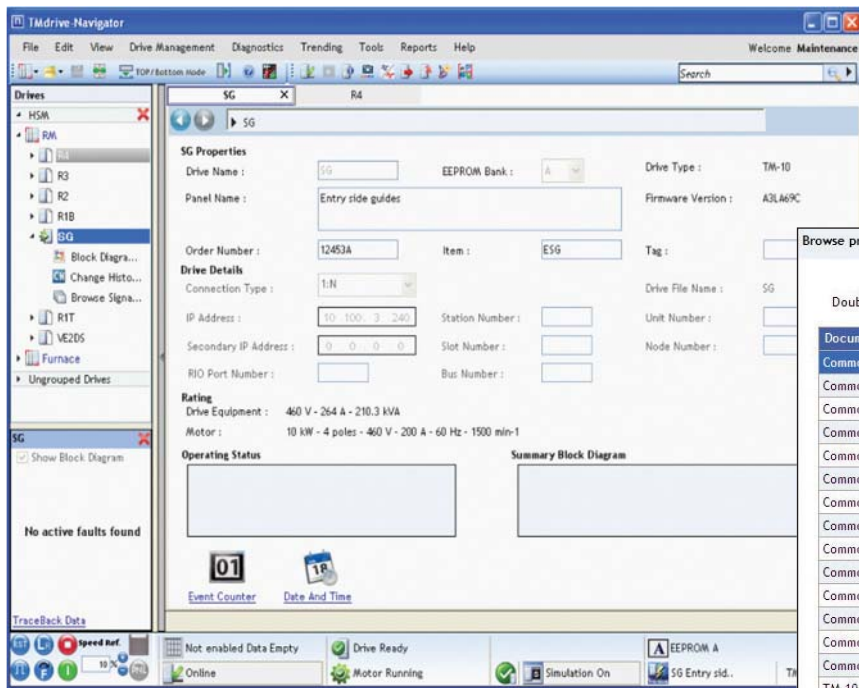

The TMdrive-Navigator tool helps you maintain TMEIC drives yourself. Engineers and technicians are empowered to understand how the drive works and what the drive is doing. Any user can easily access current drive expertise and know-how.

Desk-top like search technology links topical lists, block diagrams, help files, product documentation, change history, and user notes. Windows techniques facilitate navigation within a drive and across the system. The status of all drives is always in view.

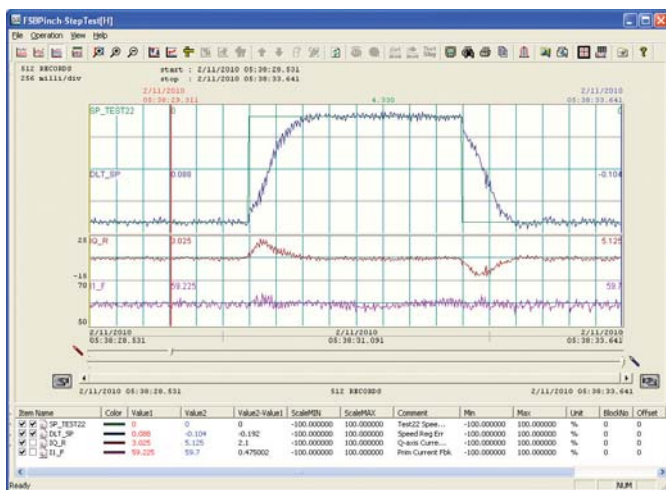
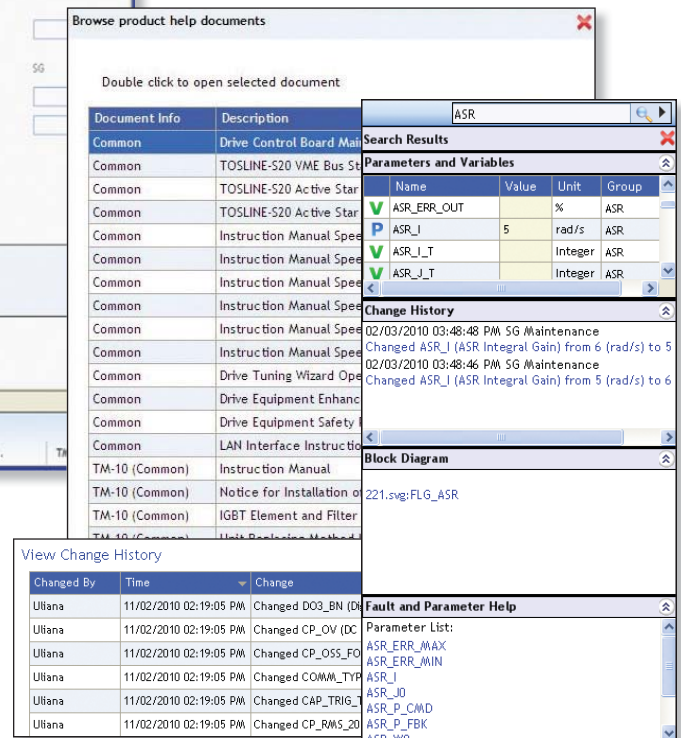

High-speed data is automatically captured and saved in the event of a drive fault. Users may also capture high speed data based on their own trigger conditions or perform high resolution real-time trending.

Fault data can be automatically “pushed” to key users. The client-server architecture allows access to high performance data from remote locations – with the same resolution as if you were in the plant.

Wizards support tuning of drive functions.

Live block diagrams provide a real-time graphical view of drive functions. Functions can be configured directly from the graphical view. Product documentation is integrated right into the tool. Users may even capture their own notes to benefit future troubleshooting.

Compatible with:

- Windows XP, Vista 7
- Windows Server 2003, 2008

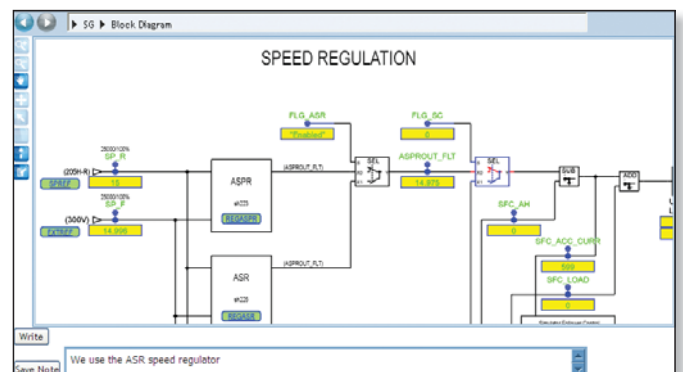

## World Class Master Controller



### PAC Systems™ RX3i

The PACSystems™ RX3i controller provides the crane control functions including logic, sequencing, and motor speed signals. The controller rack contains the power supply, CPU, and spare slots for communication and I/O cards.

#### Controller Features

#### Benefits

##### Configuring Software



The Logic Developer PLC software provides graphical programming languages including familiar ladder logic, block programming, and SFCs. Real-time data and power flow are highlighted in green.

##### Powerful and Easy to use

The choice of graphical and high-level languages makes the controller easy to use and powerful. Immediate access to all project information on the screen saves configuring time and avoids errors.

##### Fast Controller



The controller uses a 300 MHz processor and 10 Mbytes of user memory with the very fast PCI backplane.

##### More Control and Faster Response

RX3i provides more control capability in a single controller than previous controllers, and faster response to inputs.

##### Communication Options



A selection of communication Local Area Networks and I/O device networks:

- Ethernet, 10/100 MB/s
- Serial RS-232 and Serial RS-485
- Genius Bus and VersaMax
- Profibus and DeviceNet

##### Seamlessly integrates with other Control Systems

Connectivity options provide seamless integration with the rest of the dock yard systems and any existing I/O such as Series 90-30, Genius, or Profibus.

Ethernet Global Data (EGD) provides very fast communication with other devices.

##### Dual Backplane



The controller supports both the high-speed PCI backplane (32 MB/s) and Series 90-30 backplane in one assembly for convenient upgrades.

##### I/O Flexibility and Speed

PCI dual backplane is 250 times faster than 90-30 backplane and allows both RX3i and 90-30 I/O modules to be plugged in.

##### Latest I/O Modules



- High-density discrete I/O with 32 points
- High-resolution analog I/O with 16-bit accuracy
- Remove and insert modules with the power on

##### Improved Performance

Minimizes space requirements and cost and provides the highest possible control accuracy. Hot insertion simplifies repairs and reduces down time.

## Graphical Programming Simplifies Controller Configuration

Advanced graphical programming is used to configure the controller. Several different programming languages are available in the Windows-based Logic Developer PLC software, part of the Proficiency Machine Edition suite. Simple sequencing or permissive functions can be configured in relay logic. More complex control functions can be configured in a higher-level language:

- RLL (Relay Ladder Logic) blocks
- Math blocks and User Defined blocks
- Control Regulator blocks including PID
- Instruction List Blocks
- StructuredText Blocks and C programming
- Sequential Function Charts
- Diagnostics using high-speed trends of drive variables

The screenshot displays the SIMPLICITY Machine Edition software interface. The main window shows a ladder logic diagram with three rungs. Rung 1 contains an 'Enable' block, a timer 'TMR', and an 'ONDR SEC' block. Rung 2 contains an 'Enable' block, a 'Start' block, a 'Stop' block, and a 'Run' block. Rung 3 contains an 'Enable' block, a 'BrakeCm' block, and a 'ZeroSpd' block. The diagram is annotated with green lines and arrows indicating power flow.

Annotations point to various components of the interface:

- Navigator:** The project and tools in a tree structure.
- Navigator tabs:** Details of the project.
- Inspector:** Details of the selected object, (Run Enable switch).
- Companion:** A dynamic Help window.
- Editor window:** Create and edit applications.
- Editor window tabs:** Lets you switch between open editor windows.
- Data Watch:** Displays the current values and status of variables.
- Feedback Zone:** Displays output information from components.

The interface also includes a menu bar (File, Edit, Search, Project, Target, Variables, View, Insert, Data, Debug, Tools, Window, Help), a toolbar, and a status bar at the bottom showing 'Rung 2 | Run Enabled, Config EQ, Logic EQ, Sweep= 3.2 ms | Administrator LOCAL'.

The screen above shows a typical layout of the tools and editors available. The editor window shows a ladder logic diagram with real-time data and power flow displayed in green. In addition to the windows shown above, two other windows can be added:

**Toolchest:** This contains preconfigured objects that can be dragged into Machine Edition projects.

**InfoViewer:** This is an embedded browser used to display reports and comprehensive help.

## Monitoring & Diagnostic Interfaces

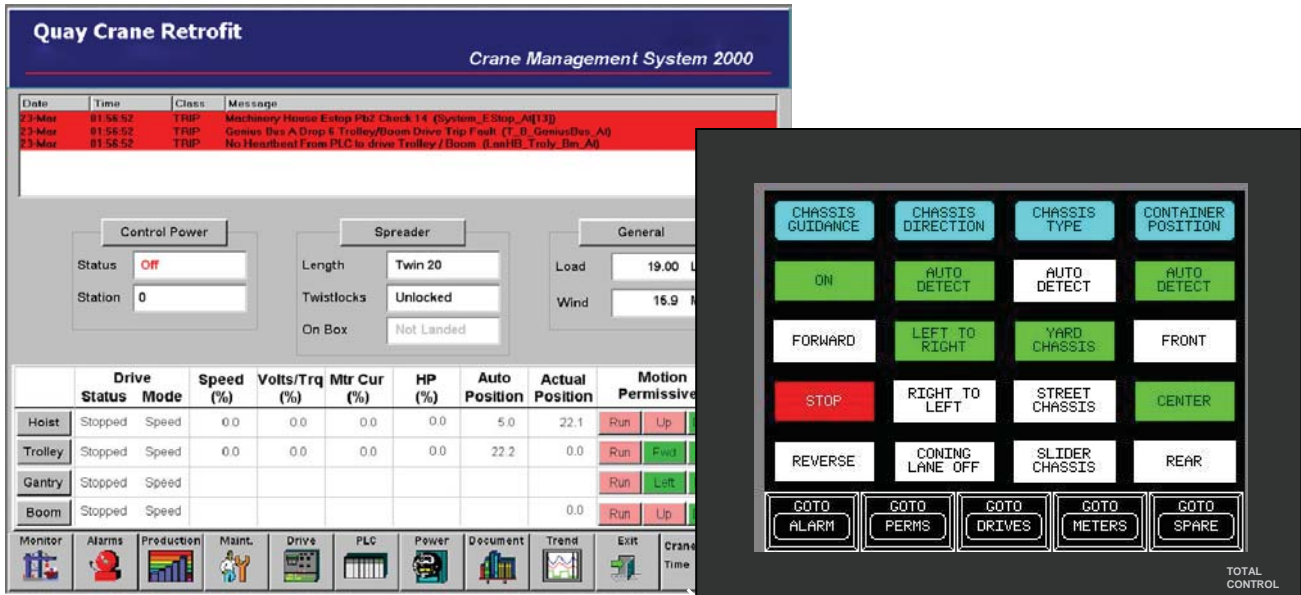

## Two HMIs for Crane Monitoring and Diagnostics

### Features



#### Small Panel-Mounted Touch Screen

Mounted in the cab or the electric house, the small touch screen station provides a selection of displays providing both real-time crane operating data and machine diagnostic data.



#### Crane Management HMI

The powerful HMI can be mounted in the electric house, the cab, ground station, or the maintenance or operations office. Buttons at the base of the screen bring up special displays for functions including:

- **Monitor:** Crane details for maintenance and operation
- **Alarms:** Details of the recent crane alarms
- **Production:** Statistics on the number of moves, whether loading or unloading, the type of loads, and the ships involved
- **Maintenance:** Records of the machine cycles, hours of operation, and maintenance schedules
- **Drive:** Toolbox software for drive configuration, tuning, performance trending, and monitoring
- **PLC:** Proficy Machine Edition software for configuring the PLC and I/O
- **Document:** Instruction manuals on all components

### Benefits

#### Convenient, Reliable Machine Control Panel

Panel-mounted close to the operator, the touch screen provides intuitive displays with data for operation and maintenance. The rugged industrial computer stands up to the yard environment.

#### A Single Station for All Functions

Versatility of the crane management HMI is a major advantage. The station can be used to operate the crane, schedule maintenance, diagnose crane problems, reconfigure the crane control system and the drives, and provide production data.

The HMI can be used by yard personnel including:

- Crane operators
- Crane maintenance
- Production personnel
- Electricians
- Crane engineers

## Crane Management System (CMS)

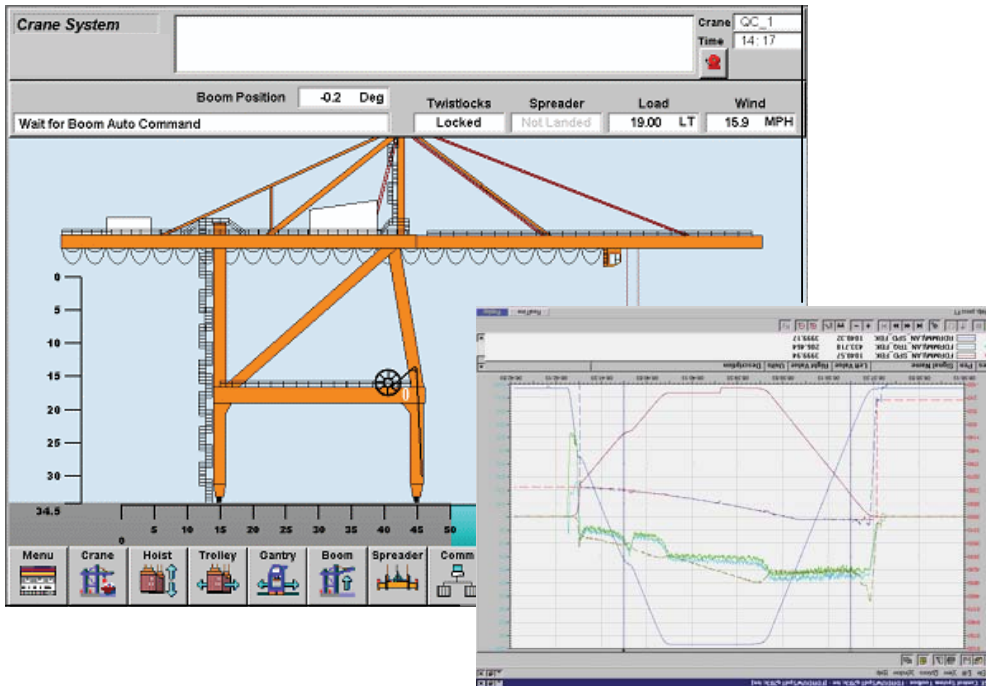

The CMS screen shown opposite is an operator overview of the entire crane with important real-time data and status information such as:

- Boom position in degrees
- Status of the twist locks
- Spreader status
- Crane load
- Wind speed

Buttons at the bottom of the screen allow the call up of displays of all crane components and control functions including:

- Hoist
- Trolley
- Gantry
- Boom (see display below)
- Spreader

Data analysis is simplified using the Trend Recorder, which displays real-time and historical data, see above right. Multiple signal traces are selected by dragging and dropping variables from the block diagram view. Movable cursors to read out values of the trends are shown at the bottom of the screen. The recorder screen shows:

- Live data from the controller trended as fast as every 20 ms
- High-speed data from capture buffers in the drive trended every one ms or faster

## Boom Status Display

Alarm List with Time and Date

Animated Graphic

Permissive Diagnostic Display

Icons for navigation to other displays

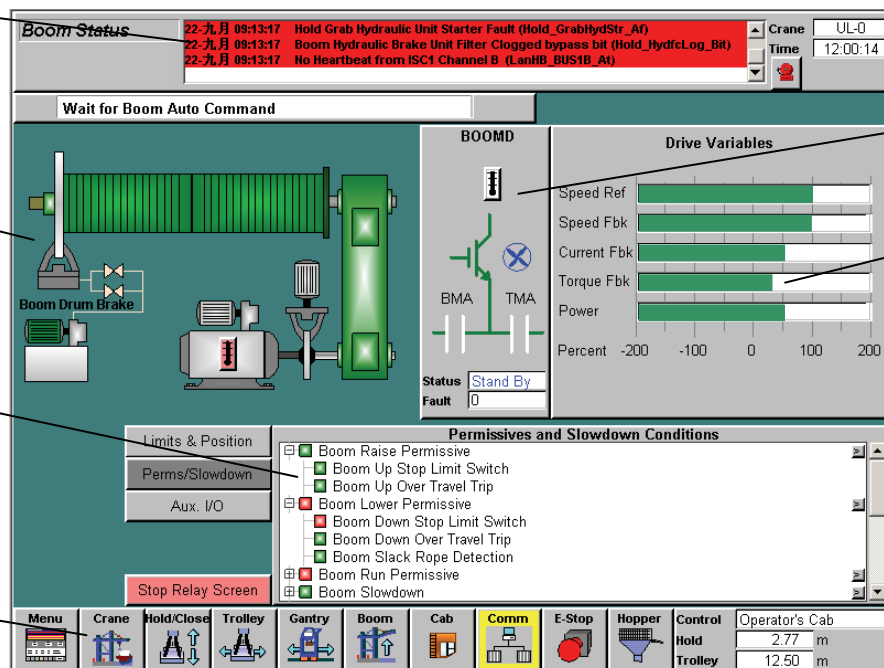

Dynamic graphic showing Power Flow

Dynamic Bar Chart Displays

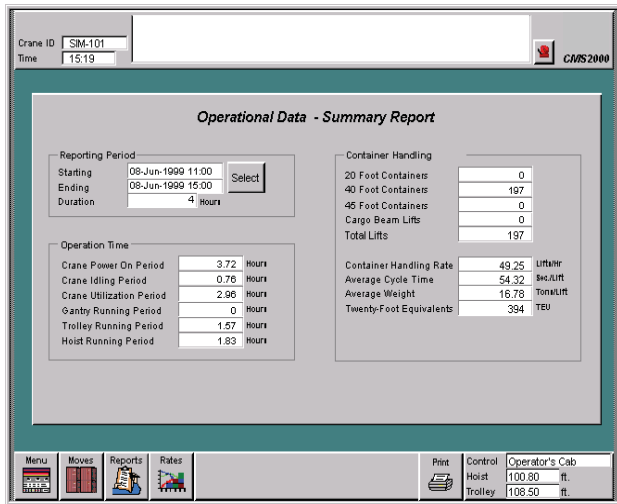

## Operation Report

The operation report, used by maintenance and technical personnel, provides performance data on individual cranes as follows:

- Operating duration in hours
- Number and type of containers lifted
- Crane utilization rate (time lifting/time with power on)
- The cycle time per container (seconds/lift)
- The average weight of container (tons/lift)
- Crane container handling rate (lifts/hour)

By adding data for all cranes, yard throughput and productivity can be calculated.

## Preventive Maintenance

This screen keeps track of the hours of operation of critical components and compares with schedule settings showing when maintenance should be performed. Alarms occur when component maintenance is required, including:

- Brake pad inspection
- A/C and vent fan service
- Twist lock inspection
- Motor brush inspection

If alarms occur, maintenance can be performed and expensive crane failures avoided. Downtime is minimized, and service is only performed when actually required.

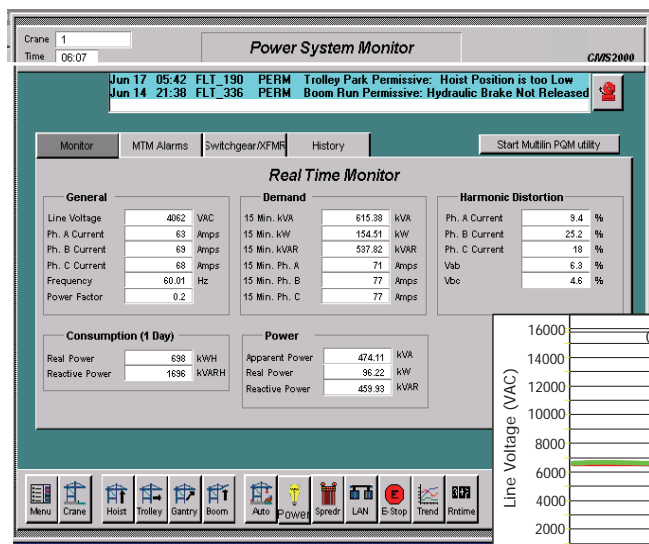
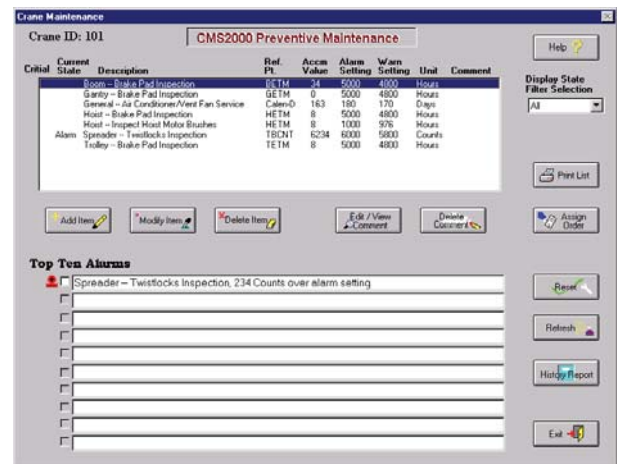

## Power System Monitor

The screen provides real-time data on the crane power supply power consumption, and harmonic distortion. This data helps:

- Protect the electrical equipment
- Reduce power consumption
- Save money on maintenance and electric power

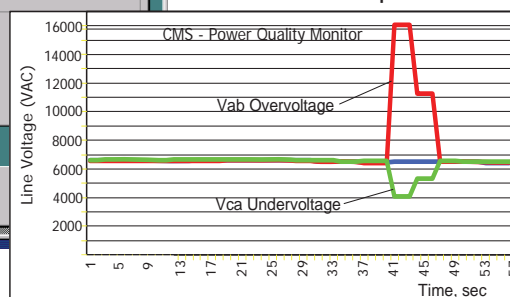

## Remote Operation

Remote operator stations in the yard office have screens with live video showing the crane pick up area and the top of the containers. Operator master switches on the desktop allow manual intervention if a problem occurs. Stations can be located on the crane or in the yard, if desired.



Remote Operator Console layout using:

- Flat screens
- Quad Video windows
- Color touchpanels
- Master switches

Alternative Operator Console layout using:

- Two screens
- Quad View video
- Desktop with pushbuttons
- Master switches

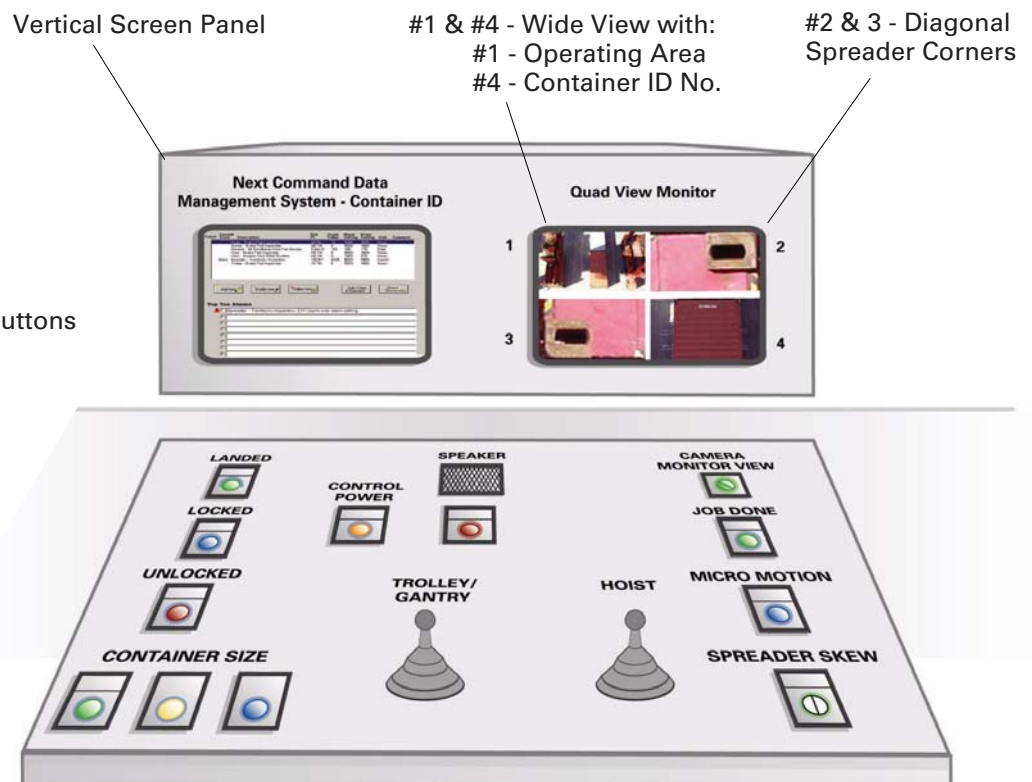

## About TMEiC

### A Global network

TMEiC is built on the combined and proud heritage of Toshiba and Mitsubishi-Electric in the industrial automation, control and drive systems business. TMEiC's global business employs more than 2,200 employees, with sales exceeding U.S. \$2.4 billion, and specializes in Metals, Oil & Gas, Material Handling, Utilities, Cement, Mining, Paper and other industrial markets.

TMEiC Corporation, headquartered in Roanoke, Virginia, designs, develops and engineers advanced automation and variable frequency drive systems.

### The factory for the World's factories

TMEiC delivers high quality advanced systems and products to factories worldwide, while serving as a global solutions partner to contribute to the growth of our customers.

### Customer Service

At TMEiC, our focus is on the customer, working to provide superior products and excellent service, delivering customer success every project, every time.

### Global Office Locations:

#### TOSHIBA MITSUBISHI-ELECTRIC INDUSTRIAL SYSTEMS CORPORATION (TMEiC)

Mita 43 MT Bldg.  
13-16 Mita 3 chome, Minato-ku  
Tokyo, Japan  
Tel: +81-3-5444-3828  
Fax: +81-3-5444-3820  
Web: [www.tmeic.co.jp](http://www.tmeic.co.jp)

#### TMEiC Europe Limited

UK (London) Tel: +44-870-950-7220  
Italy (Bari) Tel: +39-080-504-6190  
Germany (Frankfurt) Tel: +49-6968-194722  
Poland (Krakow) Tel: +48-12432-3400  
Email: [info@tmeic.eu](mailto:info@tmeic.eu)  
Web: [www.tmeic.com](http://www.tmeic.com)

#### TMEiC Corporation

Office: 1325 Electric Road  
Roanoke, VA 24018  
Mail: 2060 Cook Dr.  
Salem, VA 24153  
Tel: +1-540-283-2000  
Fax: +1-540-283-2001  
Email: [MH@tmeic.com](mailto:MH@tmeic.com)  
Web: [www.tmeic.com](http://www.tmeic.com)

#### TMEiC Industrial Systems India Private Limited

Unit #03-04, Third Floor,  
Block 2, Cyber Pearl, HITEC City, Madhapur,  
Hyderagad, Andhra Pradesh, India  
Tel: +91-40-4434-0000  
Fax: +91-40-4434-0034  
Email: [inquiry\\_india@tmeic.com](mailto:inquiry_india@tmeic.com)  
Web: [www.tmeic.in](http://www.tmeic.in)

#### TOSHIBA MITSUBISHI-ELECTRIC INDUSTRIAL SYSTEMS CORPORATION (TMEiC)

21/F, Building B, In.do Mansion  
48 Zhichunlu A, Haidian District  
Beijing, China  
Tel: +86-10-5873-2277  
Fax: +86-10-5873-3208  
Email: [sales@tmeic-cn.com](mailto:sales@tmeic-cn.com)  
Web: [www.tmeic-cn.com](http://www.tmeic-cn.com)

#### TOSHIBA MITSUBISHI-ELECTRIC INDUSTRIAL SYSTEMS CORPORATION (TMEiC)

Shanghai, China  
Email: [sales@tmeic-cn.com](mailto:sales@tmeic-cn.com)  
Web: [www.tmeic-cn.com](http://www.tmeic-cn.com)

#### TMEiC Asia Company Ltd.

Kowloon Bay, Hong Kong  
Web: [www.tmeic.com](http://www.tmeic.com)

#### TMEiC Asia Company, Ltd. Rep. Office

Kaohsiung, Taiwan  
Web: [www.tmeic.com](http://www.tmeic.com)

TMdrive is a trademark of TOSHIBA MITSUBISHI-ELECTRIC INDUSTRIAL SYSTEMS CORPORATION.

Maxspeed is a trademark of TMEiC Corporation.

Maxview is a trademark of TMEiC Corporation.

All specifications in this document are subject to change without notice. This brochure is provided free of charge and without obligation to the reader or to TMEiC. TMEiC does not accept, nor imply, the acceptance of any liability with regard to the use of the information provided. TMEiC provides the information included herein as is and without warranty of any kind, express or implied, including, but not limited to, any implied statutory warranty of merchantability or fitness for particular purposes. The information is provided solely as a general reference to the potential benefits that may be attributable to the technology discussed. Individual results may vary. Independent analysis and testing of each application is required to determine the results and benefits to be achieved from the technology discussed.